

Operating instructions

english
for

S7-Interface-Cable:

MPI/PPI
MPI-II, MPI-LAN, MPI-USB
MPI-MODEM, S5ToMPI
MPI-NETZ-Adapter
MPI-Cablemanager

S5-Interface-Cable :

PG-COM
PG-UNI
PG-UNI-II
PG-USB
USB-Serial-Converter

Adapter for PG-UNI / PG-UNI-II :

Netz-Adapter
PG-ISO-Adapter
CP525-Adapter
CP525-K-Adapter
SINUM-Adapter
AG-150-Adapter
WF470-Adapter

Mitsubishi-Interface-Cable:

SC-09

Version 3.6

© Copyright 1996-2008 by PI

Contents

1 MPI/PPI	10
1.1 Functional Description	10
1.2 MPI/PPI as TS-Adapter	11
1.3 MPI/PPI as HMI-Adapter	12
1.4 Pin assignment.....	13
1.4.1 Pinning RS232 (PC-side)	13
1.4.2 Pinning MPI (PLC-side).....	14
1.5 Connecting the cable.....	15
1.6 The display	16
1.7 Technical data	17
1.8 Tips and Troubleshooting MPI/PPI-Cable	19
1.9 Accessories: MPI-NETZ-Adapter	23
1.9.1 Circuit diagram MPI-NETZ-Adapter	23
2 MPI-II	24
2.1 Functional Description	24
2.2 MPI-II as TS-Adapter.....	24
2.3 MPI-II as HMI-Adapter	26
2.4 Pin assignment.....	27
2.4.1 Pinning RS232 (PC-side)	27
2.4.2 Pinning MPI (PLC-side).....	28
2.4.3 External Power-Connector	29
2.5 Connecting the cable.....	30
2.6 Display and Keyboard of the MPI-II Cable.....	31
2.6.1 The Keyboard.....	33
2.6.2 Main Menu.....	34
2.6.3 Info	34
2.6.3.1 Version	34
2.6.4 Bus	35
2.6.4.1 Adressen	35
2.6.5 Config.....	36
2.6.5.1 Mode	36
2.6.5.2 USBStrom	37
2.6.5.3 Data.....	38
2.6.5.4 MPI-BUS	38
2.6.5.4.1 Baudrate	39

2.6.5.4.2 HSA.....	40
2.6.5.4.3 local Nr.....	40
2.6.5.5 PG/PC.....	40
2.6.5.5.1 Baudrate.....	41
2.6.5.6 Protocol.....	41
2.6.5.7 Language.....	42
2.6.5.8 in Flash.....	42
2.6.5.9 Set Def.	43
2.7 Software-Installation for USB.....	43
2.7.1 Siemens-S7 / PG-2000.....	43
2.8 Technical data.....	44
3 S5TOMPI.....	45
3.1 Functional-Description.....	45
3.2 Connecting the Interface.....	45
3.3 Configuration on the Cable.....	46
3.3.1 Mode.....	46
3.3.2 S7Config.....	47
3.3.2.1 CPU.....	48
3.3.2.1.1 StatNumr.....	48
3.3.2.1.2 SlotNr.....	49
3.3.2.1.3 Function.....	49
3.3.2.2 MPI Bus.....	50
3.3.2.2.1 Address.....	50
3.3.2.2.2 Profile.....	51
3.3.2.3 SPSFlag.....	51
3.3.2.4 Comm DB.....	52
3.3.3 S5Konfig.....	52
3.3.3.1 CPU.....	53
3.3.3.2 SPSFlag.....	53
3.3.3.3 Comm DB.....	53
3.4 The Display.....	54
3.4.1 Display.....	54
3.4.2 Error messages.....	55
3.5 SPS-Flag.....	57
3.5.1 the commandbyte.....	57
3.5.2 the status byte.....	57
3.6 the communications-data block.....	58
4 MPI-USB.....	60
4.1 functional description.....	60

Handbook Cable & Adapter

4.2	MPI-USB as HMI-Adapter	60
4.3	Pinning.....	61
4.3.1	Pinning USB (PC-side).....	61
4.3.2	Pinning MPI (PLC-Side)	61
4.3.3	External powersupply	62
	Connecting the adapter.....	63
4.4	Display and Keyboard of the MPI-USB cable	64
4.4.1	The keyboard	65
4.4.2	Main menu.....	66
4.5	Installation of the software for the MPI-USB cable	67
4.5.1	Siemens-S7 / PG-2000	67
4.6	Technical data	68
5	MPI-LAN.....	69
5.1	Functional description.....	69
5.2	Connecting the cable.....	69
5.3	Display and keyboard of the MPI-LAN.....	70
5.3.1	The Keyboard.....	72
5.3.2	Main menu.....	73
5.3.3	Info	73
5.3.3.1	Version	74
5.3.4	Bus	74
5.3.4.1	Adresses	75
5.3.5	Config	76
5.3.5.1	Mode	77
5.3.5.2	MPI.....	77
5.3.5.2.1	Baudrate	78
5.3.5.2.2	HSA.....	78
5.3.5.2.3	LocalNr.....	79
5.3.5.3	Language	79
5.3.5.4	In Flash	80
5.3.5.5	Erase.....	80
5.3.5.6	IP-Adr	80
5.3.5.7	Protocol	81
5.3.5.8	Password	81
5.4	Technical data	82
6	PLC-VCOM APPLICATION	83
6.1	Functional Description	83
6.2	Installation of PLC-VCom	83

6.3	Setting up PLC VCom / using PLC VCom	84
6.3.1	Setting up PLC-VCom for Cables.....	85
7	MPI-MODEM.....	89
7.1	Description.....	89
7.2	MPI-Modem as TS-Adapter.....	89
7.3	TeleService Function.....	90
7.3.1	Setting up the hardware	90
7.3.2	Configure the MPI – Modem	90
7.3.3	TS – Software Configuration	91
a.	SIMATIC Step7 v5.3 with TeleService v6.0	91
b.	MPI – Cablemanager v2.07	95
7.4	Pin assignment.....	97
7.4.1	Pinning RS232 (PC-side)	97
7.4.2	Pinning MPI (PLC-side).....	98
7.4.3	External power connector.....	99
7.4.4	Light emitting diode's.....	100
7.4.5	Analogue phone connector	101
7.5	Connecting the MPI-Modem.....	102
7.6	Display and keyboard of the MPI-Modem.....	102
7.6.1	The keyboard	106
7.6.2	Main menu.....	107
7.6.3	Info	107
7.6.3.1	Version	108
7.6.3.2	Signalquality.....	108
7.6.3.3	Signallevel.....	108
7.6.4	Bus	109
7.6.4.1	Adresses	109
7.6.5	Config.....	110
7.6.5.1	PG/PC	110
7.6.5.1.1	MPI Accs.....	111
7.6.5.1.2	PPI-Accs	112
7.6.5.1.3	TrnModem (transparent modem mode)	113
7.6.5.1.4	ExtModem (external modem mode).....	114
7.6.5.2	Data.....	115
7.6.5.3	Modem	115
7.6.5.3.1	Dial mode.....	116
7.6.5.3.2	phone book	116
7.6.5.3.3	baudrate.....	117
7.6.5.3.4	Modemtype	117

Handbook Cable & Adapter

7.6.5.3.5	Speaker.....	118
7.6.5.3.6	Busy identification	118
7.6.5.3.7	Ring counter.....	119
7.6.5.3.8	Extension	119
7.6.5.3.9	Outline code.....	119
7.6.5.4	MPI-Bus	120
7.6.5.4.1	Baudrate	120
7.6.5.4.2	HSA.....	121
7.6.5.4.3	Local nr.	121
7.6.5.4.4	Master	122
7.6.5.4.5	Profil.....	122
7.6.5.5	Protocol	123
7.6.5.6	Language	124
7.6.5.7	Erase.....	124
7.6.5.8	Reset.....	124
7.6.5.9	Password	125
7.6.5.10	Telemessage (optional).....	125
7.6.5.10.1	SMS	126
7.6.5.10.2	Fax.....	127
7.6.5.10.3	Voice	128
7.6.6	Hang up.....	128
7.6.7	Call	128
7.7	Technical data	130
8	THE S7-INTERFACE-CONFIGURATOR (S7IFC)	131
8.1	Menubar	131
8.2	Properties	132
8.3	Buttons	132
8.4	Display.....	133
9	THE MPI-CABLEMANAGER	135
9.1	Language.....	135
9.2	Interface.....	136
9.3	Update	137
9.4	Teleservice	139
9.4.1	Telephone-Book	139
9.4.2	Connect.....	140
9.4.3	Extra	141
9.4.3.1	Setup	144
9.4.3.2	TS-function	144
9.4.3.3	Adapter configuration	145

9.4.3.3.1	Network	145
9.4.3.3.2	Modem.....	147
9.4.3.3.3	Serial parameter	149
9.4.3.3.4	Password.....	150
9.4.3.4	GSM / ISDN /SMS.....	152
9.4.3.4.1	GSM-Modem.....	152
9.4.3.4.2	ISDN-Modem	154
9.4.3.4.3	Analog-Modem.....	156
9.4.3.4.4	Messages.....	156
9.4.3.4.5	SMS-Processing	159
9.4.3.5	Import configuration.....	160
9.4.3.6	Export configuration.....	160
9.5	Tuning.....	161
9.6	Connection of a TS-Adapter	164
9.7	Update over Tele-Network.....	165
9.8	Connecting the A20 Terminal	167
9.9	Siemens-Original-Software and MPI/PPI/HMI/TS-Adapter with 115200 Baud.....	168
9.9.1	MPI Speed-TrayIcon	170
10	PG-COM / PG-UNI / PG-UNI-II	173
10.1	Operatin Instruction.....	173
10.2	Circuit diagram PG-COM	174
10.3	Circuit diagram PG-UNI	175
10.4	Circuit diagram PG-UNI-II	176
11	PROLONGATION OF PG-UNI AND PG-UNI-II..	177
12	UNI-PROLONGATION-SET	177
13	PG-USB.....	177
13.1	Pinning.....	178
13.2	PG-USB-prolongation	178
13.3	Driver-Installation	179
13.4	Original-S5 in a MS-DOS-Box.....	180
13.5	Driver for Windows 98.....	182
13.5.1	Installation.....	182
13.5.2	Deinstallation	183
13.5.3	Configuration / Start.....	183

Handbook Cable & Adapter

13.5.4	Frequently asked questions.....	186
14	USB-SERIAL-CONVERTER.....	191
14.1	Description	191
14.2	Driver installation	191
15	ADAPTORS FOR PG-UNI / PG-UNI-II / PG-USB	192
15.1	Netzadapter (not for PG-USB):	192
15.1.1	Circuit diagram NETZ-Adapter	193
15.2	PG-ISO-Adapter.....	194
15.2.1	Circuit diagram PG-ISO-Adapter	194
15.3	CP525-Adapter	195
15.3.1	Plug design	195
15.4	CP525-Adapter for PG-USB	195
15.4.1	Plug design	195
15.5	CP525-K-Adapter.....	196
15.5.1	Plug design	196
15.6	CP525-K-Adapter for PG-USB.....	196
15.6.1	Plug design	196
15.7	SINUM-Adapter.....	197
15.7.1	Plug design	197
15.8	SINUM-Adapter for PG-USB.....	197
15.8.1	Plug design	197
15.9	AG150-Adapter	198
15.9.1	Plug design	198
15.10	AG150-Adapter for PG-USB	198
15.10.1	Plug design	198
15.11	WF470-Adapter.....	199
15.11.1	Plug design	199
15.12	WF470-Adapter for PG-USB.....	199
15.12.1	Plug design	199
15.13	25pol. PC-Connector (male/female).....	200
15.14	Special Versions	200
16	RELEASE TABLE	201
17	SC-09	202
17.1	Pin configuration RS232	202
17.2	Pin configuration RS422/485	203

17.3 Plug design204

1 MPI/PPI

1.1 Functional Description

The MPI/PPI-Cable connects the programming-device or a PC over the serial port (COM- Interface) with the MPI-Interface of a S7-300/400 also with the PPI-Interface of a S7-200.

The cable finds by himself what a kind of PLC is plugged in and the required baud rate in the first time of communication of the connected programming-device or PC. In operation with the programming software PG-95/2000 or S7-for-Windows, the cable will work up to 115.2 kBaud at his PC-side.

The MPI/PPI-Cable works with the current output voltages of the PLC and doesn't need any external voltages. The internal electronic (and RS232) to the bus driver and also to the 24V input are decoupled.

1.2 MPI/PPI as TS-Adapter

TS (Tele Service)

The TS-possibility allows the connection of a modem, to make a connection with a 2nd Modem and a PC to a S7-300/400. The Cable must be connected between the modem (with a special adapter piece, no Gender-Changer) and the PLC. To work with the MPI-Cable in his TS-function, you must make the following actions:

- 1) The cable must be configured as a TS-Adapter (instead of “PG” or “Pg” the LCD display shows “TS” or “Ts”). You can turn on/off these function with the free program “MPI-Kabel Manager”.
- 2) The program inside of the cable must have a version greater than V1.45. This version number will be displayed for a short time behind the plugging to a S7 PLC. You can update the cable software with the free program “MPI-Kabel Manager”.
- 3) You need the TeleService-software from Siemens in your PC to work with the cable. The configuration of the cable can be made with the TeleService-software from Siemens or with the “MPI-Kabel Manager”.
- 4) **The connection of the modem to the MPI-cable must made with a special adapter plug (no Gender-Changer or so)**

Order Description

MPI / PPI – Cable 3m	Order.No. 9350
MPI / PPI – Cable 5m	Order.No. 9350.05m
MPI / PPI – Cable 10m	Order.No. 9350.10m
MPI / PPI – Cable 15m	Order.No. 9350.15m
Power Supply for MPI-Cable	Order.No. 9350-4
Interfacecable 9pin to Modem	Order.No. 9350-TS
T-Connector to MPI / PPI - Bus	Order.No. 9361-7

The adapter for the TS-function only works with the MPI / PPI – Cable with the order-number 9350 !

1.3 MPI/PPI as HMI-Adapter

HMI (Human Machine Interface):

The HMI-possibility allows the connection of a operator panel (who has not an internal MPI-port, but the HMI-protocol and a RS232-interface) with a S7-300/400. The cable must be connected between the operator panel and the PLC. The HMI-protocol must be a part of the operator panel.

Behind the version V1.45 of the software inside the cable, you can use the cable as a HPI adapter. Some operating panels are made to work with a **Siemens-HMI-Adapter**. The pinning to our cable is different. You may turn the wires 2 and 3 in a little adapter. Please look into the handbook of the operator panel what you need for the correct pinning.

1.4 Pin assignment

1.4.1 Pinning RS232 (PC-side)

Pin No.	Notation	Signalname	Direction (of cable)
1	DCD	Data Carrier Detect	Out
2	TXD	Transmitted Data	Out
3	RXD	Received Data	In
4	DSR	Data Set Ready	In
5	GND	Signal Ground	
6	DTR	Data Terminal Ready	Out
7	CTS	Clear to Send	In
8	RTS	Request to Send	Out
9	NC	Not Connected	
Shield		On connector casing	

The shield is connected with the RS232 connector via the shield of the adapter casing. This cable is designed to be connected directly on a COM interface of a PC. The cable can be lengthened by a 1:1-cable to the PC up to 15m maximum. The cable should have a good quality and the shield should be connected at both sides at the SUB-D case.

1.4.2 Pinning MPI (PLC-side)

Pin No.	Notation	Description	Direction (of cable)
1	NC	Not Connected	
2	M24V	Ground of the 24V	In
3	Ltg_B	Data line B	BiDir.
4	RTS-AS	Request to Send from the PLC	In
5	M5V	Ground of the 5V	In
6	P5V	5V output	Out
7	P24V	24V Supply input	In
8	Ltg_A	Data line A	BiDir.
9	RTS-PG	Request to Send to the PLC	Out
Shield		On connector casing	

The shield is attached with the MPI/PPI connector via the shield of the adapter casing. To find directly attended PLC's, RTS-AS and M5V must be connected in the cable. P5V means a output of the cable and works only as an output for a bus-termination with resistors. This 5V output doesn't drive any load and have a 100R resistor inside his direction.

Attention:

Don't lengthen the connection by a 1:1 cable to the PLC, because there are 24V and 5V inside of the cable. The quality of the bus-signal will be risen down!

To lengthen the connection, please use a MPI-NETZ-Adapter and connect only the signals Ltg_A and Ltg_B 1:1 and the shield at both sides of the metal-casing at the SUB-D connector

1.5 Connecting the cable

This cable will be connected with his short side to the MPI- or the PPI-Interface of the PLC. The MPI/PPI-Cable works with the current output voltages of the PLC and doesn't need any external voltages. The cable requires a PLC to get the 24V out of it. You can use an optional power supply to work with an external 24V voltage. So the cable can be lengthen.

The longer side of the cable must be connect with the programming-device or with an PC to the COM-Port.

When the MPI/PPI-Cable gets the power it shows the software-version in the display and begins with the test of its internal components. Then it checks the bus if there is a PLC on a MPI-bus or on a PPI-bus connected.

If the connected bus is a PPI-Bus, the cable will set its transfer rate at its acquirements. If it finds a MPI-PLC he set its transfer rate at the MPI-Bus confirmed baud-rate. On the display all relevant data is displayed.

The cable will find at a MPI-Connection the active baud rate to the programming-device or to the PC in the first time of communication and set his baud rate himself.

If you want to connect the cable to the 25-pin connector of the PC, you can use an adapter (9 pin to 25 pin sub miniature D-connector) to work with this port.

In the PC-Software you must adjust some parameters like the baud rate (19,2 or 38,4 kbaud) and the connected COM-PORT (COM1 or COM2) and the used adapter as 'PC-Adapter'.

1.6 The display

In that LCD-Display all relevant working parameters of the cable will be reported.

Example of Display:

	Number of the bus-participants	PG-Communication Baudrate-Selection (see bottom)	Participant-number of the connected PG/PC	PG communication ■ to the cable ■ to the PG/PC
#	01	PG	00	■
!	04	AG	04	
! = the displayed PLC is directly connected ? = the displayed PLC is not directly connected	There will be the founded bus-participants displayed (the active ones)		Participant-number of the PLC, you just work with it	

Baudrate - Modes

PD	115.2kBaud or automatic Baud rate – Selection
TD	115.2kBaud or automatic Baud rate – Selection if TS
PG	38.4kBaud
TS	38.4kBaud if TS
Pg	19.2kBaud
Ts	19.2kBaud if TS
pG	57.6kBaud
tS	57.6kBaud if TS

1.7 Technical data

Description	Technical Specifications
Dimensions without cables	146 x 41x 29mm (l x w x h)
Case type	ABS, V0
Cable type	UL2464, 28AWG, double shielded
Interfaces To the MPI-BUS To the PPI-BUS To the PG/PC	RS485 (187,5 kbaud) RS485 (9,6 and 19,2 kbaud) RS232 19,2 kbaud or 38,4 kbaud 115,2 kBaud with PG-95/2000
Supply voltage	DC 24V +/- 20% The 24V will be taken out of the connected PLC or of the connected adapter.
Power disurpation	I=80mA (typ)
Output current 5V	This 5V output doesn't drive any load and have a 100R resistor in his series. Use it only as bustermination.

Handbook Cable & Adapter

Type of protection	IP20
Galv. decoupling	The internal electronic (and RS232) to the bus driver and also to the 24V input are decoupled. The shield from the MPI/PPI side to the RS232 side are through connected

1.8 Tips and Troubleshooting MPI/PPI-Cable

The MPI-Cable shows PPI but it is connected to a S7-300/400 PLC:

At the first using of a new PLC, it can occur that the cable shows in its display PPI. The fact is that the PLC wants to have the first reset to be initialised, to make a communication over the MPI-bus. The plug in and the plug out of the batteries or flash-cards make the same problems with the PLC at its MPI-bus. So you must make a reset. You can see it when the STOP-LED flashes (with long impulses), SF-LED is set, eventually the BATF-LED, too.

The reset of a S7-PLC:

- 1) Key switch round about 3 sec to the position MRES (the STOP-LED flashes, then continuous light)
- 2) Stop holding the key switch, switch then after a short time to the position MRES back (the STOP-LED flashes fast, then continuous light)
- 3) Turning the key switch to RUN-P (the STOP-LED stops lightning and the RUN-LED starts lightning)

That's it

Now the reset of the PLC is over, the PLC is ready to work with the MPI-bus, the MPI/PPI-Cable will work now with the PLC it can be plugged and will find the PLC with the station-address 2.

The MPI-Cable shows nothing on the display:

The MPI/PPI-Cable needs 24V out of the PLC to work. Please take care that there is 24V. For example, the Sinumerik have none. If there is no 24V output at the MPI-bus connector, you should use the MPI-Netzadapter. You must use him too if you want to make a long cable between the MPI/PPI-Cable and the PLC because it is not allowed to make a long connection with power supplying in the cable (look at the point MPI-Netzadapter for details).

The MPI/PPI-Cable displays the first line its display correctly, but in the second row „? AG “:

The MPI-Cable shows that a MPI-bus is connected but it can not receive any correct data. The fact can be that someone have changed the hardware-configuration of the CPU. The MPI baud rate **must** have 187,5kBaud or 19,2kBaud that the MPI-Cable can make a communication with the PLC. Please take care that the baud rate in the hardware-configuration is turned back to 187,5kBaud or 19,2kBaud.

The MPI/PPI-Cable displays correct data but the connection to the programming software does not work correctly:

- 1) The cable finds by himself what a kind of PLC is plugged in and the required baud rate in the first time of communication of the connected programming-device or PC. If you switch the baud rate in your software, the cable does not recognize that not immediately, the cable want to communicate with the first setting. Retry it.
- 2) Take a look into your programming-software for the COM settings and the installed adapter-type

- 3) Do you use the MPI-Cablemanager and have selected the TS function in the cable? Please use the MPI-Cablemanager to switch back to the normal function of the cable or select the driver „TS-Adapter“ with „Access“ defined to direct.
- 4) Is there any other application in the background of your system that uses the same COM port, too? If yes, please close that program.

Bus-informations und Cable-version without plugged PC:

You must plug the cable into a PLC and in the first time the cable shows his software version, and then it shows all important businformations (look also to the point “The display”).

The programmingsoftware displays all PLCs in the MPI system, and can make a connection to the PLC, but you can not open or save a block:

Look at the number of the PLC who you have selected in your hardware-configuration. The numbers are different. Transfer the Hardwareconfiguration or make new settings.

The Cable is connected on a S7-300/400 , but it displays for a few time PPI when you switch on the PLC:

In the moment of power on, the MPI bus does not be driven from the PLC, so the cable thinks that must be a PPI PLC. But if the PLC is ready with his start up, it will drive the MPI bus and will give the cable the protocols. Now the cable will

Handbook Cable & Adapter

switch his display from PPI to the right MPI text. That can be for approximately five seconds.

Programming over the Profibus

It is possible to program a PLC over the PROFIBUS, to do this the following must reside:

- 1.) In the Hardware-Configuration the Destination-PLC the PROFIBUS-Protocol-Type must be set to „Default“ or „DP/FMS“.
- 2.) The MPI-Cable needs when connected to a 2-wire-cable (passive Station) an external 24V power supply
- 3.) The local station-address must be unique
- 4.) The PROFIBUS-Baud rate must be possible with the MPI-Cable

It is to notice, that the Profibus-Cycle-Time is lengthen (more stations in bus), The Destination PLC must be changed the Hardware-Configuration.

Wachendorff Panel / HMI does not connect within a minute.

In the MPI-Cablemanager select the tab „Tuning“. Set „HMI-Version“ and in the Boot-setting select „MPI“. Transfer to the cable

1.9 Accessories: MPI-NETZ-Adapter

The MPI-NETZ-Adapter generates the power supply for the MPI/PPI-Cable, so you can connect this cable with a 2-wire connection to the PLC. You must connect only the signals Ltg_A and Ltg_B 1:1 and the shield at both sides of the metal-casing at the SUB-D connector

1.9.1 Circuit diagram MPI-NETZ-Adapter

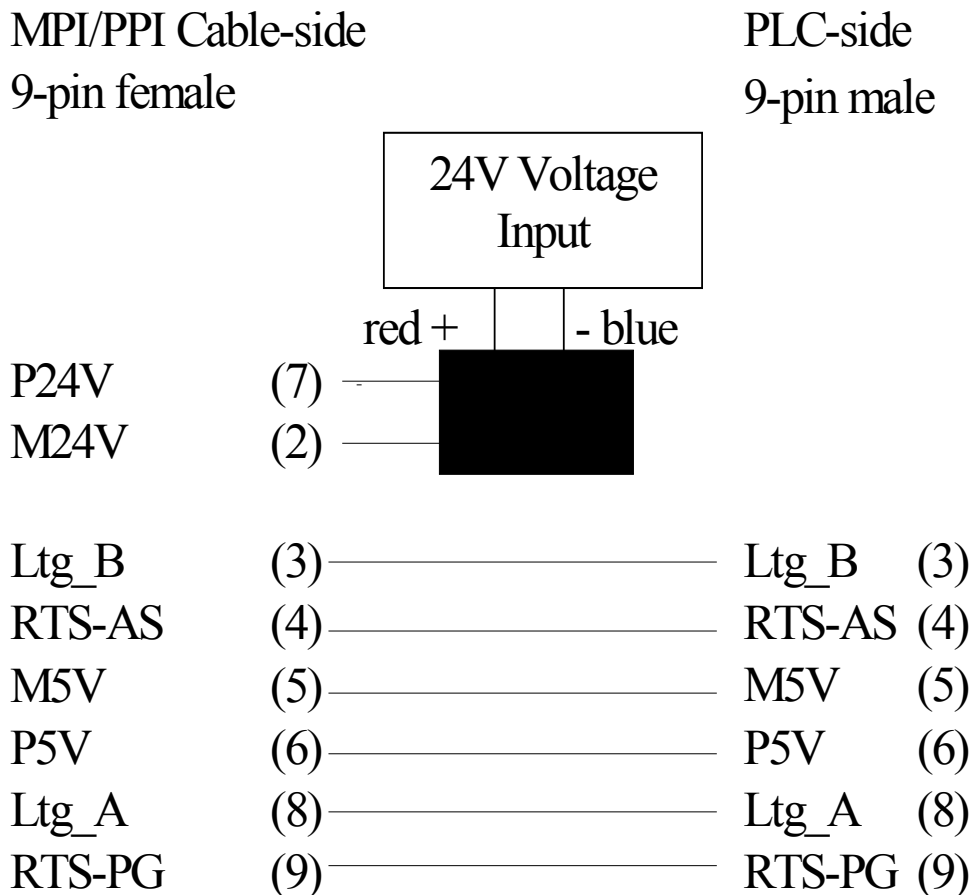

The Shield is connected at both SUB-D metallcasing

2 MPI-II

2.1 Functional Description

The MPI-II-Cable connects the programming device or PC over the serial Interface (COM-Port) or the PC over the USB-Bus with the MPI- or DP/FMS-Connector of the S7-300/400 PLC. The Cable selects automatically on the first access which Port and which Baud rate is used. With our PLC-Programming-Application PG-95/PG-2000 or S7-for-Windows works the MPI-II-Cable with up to 115.2kBaude on the PC - Side. Dedicated for Siemens-Applications the MPI-Speed-driver is delivered, which could use Baudrates up to 115.2 kBaude. Together with the VCOM-driver you could program your PLC over the USB-Port of the PC.

On the MPI-Side you could use Baud rates from 19k2 up to 12Mbaude. The Baudrates 3M,6M and 12Mbaude could only used when configured on the MPI-II-Cable by keyboard. An automatic selection of the MPI-Baudrate is possible.

The MPI-II-Cable is power-supplied from the PLC and needs then no external supply. Over an external connector it is possible to supply 24V to the Cable (if the Connection has only the 2 Data-Lines). All Voltages are decoupled together (24V Input to MPI-Bus and internal Power-Supply).

2.2 MPI-II as TS-Adapter

TS (Tele Service)

The TS-function allows the connection of a modem, to make a dial-up-network connection with a 2nd Modem and a PC to a S7-300/400. The Cable must be connected to TS-Adapter (with a special pinning, **no** Gender-Changer) which is between the modem and the PLC .

To work with the MPI-II-Cable in his TS-function, you must make the following actions:

- 1) The cable must be configured as a TS-Adapter (instead of “PG” or “Pg” the LCD display shows “TS” or “Ts”). You can turn on/off these function with the free program “MPI-Cable Manager”.
- 2) You need the TeleService-software from Siemens in your PC to work with the cable. The configuration of the cable can be made with the TeleService-software from Siemens or with the “MPI-Kabel Manager”.
- 3) **The connection of the modem to the MPI-II-cable must made with a special adapterplug (no gender-changer or so)**

Order Description

Interfacecable 9pin to Modem Order.No. 9350-TS

The adapter for the TS-function only works with the MPI-II Cable with the order-number 9352 !

2.3 MPI-II as HMI-Adapter

HMI (Human Machine Interface):

The HMI-possibility allows the connection of a operator panel (who has not an internal MPI-port, but the HMI-protocol and a RS232-interface or USB) with a S7-300/400. The cable must be connected between the operator panel and the PLC. The HMI-protocol must be a part of the operator panel.

Behind the version V1.45 of the software inside the cable, you can use the cable as a HPI adapter. Some operating panels are made to work with a **serial Siemens-HMI-Adapter**. The pinning to our cable is different. You may turn the **wires 2 and 3** in a little adapter. Please look into the handbook of the operator panel what you need for the correct pinning.

This applies **NOT** to HMI-Terminals which are connected over USB.

2.4 Pin assignment

2.4.1 Pinning RS232 (PC-side)

Pin No.	Notation	Description	Direction (of cable)
1	DCD	Data Carrier Detect	Out
2	TXD	Transmitted Data	Out
3	RXD	Received Data	In
4	DSR	Data Set Ready	In
5	GND	Signal Ground	
6	DTR	Data Terminal Ready	Out
7	CTS	Clear to Send	In
8	RTS	Request to Send	Out
9	RI	Ring Indicator	In
Shield		On connector casing	

The shield is connected with the RS232 connector via the shield of the adapter casing. This cable is designed to be connected directly on a COM interface of a PC. The cable can be lengthened by a 1:1-cable to the PC up to 15m maximum. The cable should have a good quality and the shield should be connected at both sides at the SUB-D case.

2.4.2 Pinning MPI (PLC-side)

Pin No.	Notation	Description	Direction (of cable)
1	NC	Not Connected	
2	M24V	Ground of the 24V	In
3	Ltg_B	Data line B	BiDir.
4	RTS-AS	Request to Send from the PLC	In
5	M5V	Ground of the 5V	In
6	P5V	5V output	Out
7	P24V	24V Supply input	In
8	Ltg_A	Data line A	BiDir.
9	RTS-PG	Request to Send to the PLC	Out
Shield		On connector casing	

The shield is attached with the MPI connector via the shield of the adapter casing. To find directly attended PLC's, RTS-AS and M5V must be connected in the cable. P5V means a output of the cable and works only as an output for a bus-termination with resistors. This 5V output doesn't drive any load and have a 100R resistor inside his direction.

Attention:

Don't lengthen the connection by a 1:1 cable to the PLC, because there are 24V and 5V inside of the cable. The quality of the bus-signal will be risen down!

To lengthen the connection, please use a MPI-NETZ-Adapter and connect only the signals Ltg_A and Ltg_B 1:1 and the shield at both sides of the metal-casing at the SUB-D connector, insert eventually Terminating-Resistors (at END of Bus).

2.4.3 External Power-Connector

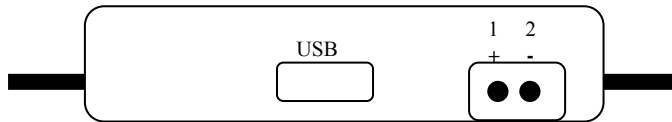

Description	Notation	In/Out (of Cable)	Pin No.
24V Power	P24V	In	1
Ground 24V	M24V	In	2

2.5 Connecting the cable

This cable will be connected with his short side to the MPI- or the DP/FMS-Interface of the PLC. The MPI-II -Cable works with the current output voltages of the PLC and doesn't need any external voltages. The cable requires a PLC to get the 24V out of it. You can also use an optional power supply to work with an external 24V voltage. So the cable can be lengthen.

The longer side of the cable must be connect with the programming-device or with an PC to the COM-Port.

USB is connected with a Type A to A cable.

When the MPI-II-Cable gets the power it shows the software-version in the display and begins with the test of its internal components. On the display all relevant data is displayed.

The cable will find at a MPI-Connection the active baud rate to the programming-device or to the PC in the first time of communication and set his baud rate himself.

If you want to connect the cable to the 25-pin connector of the PC, you can use an adapter (9 pin to 25 pin sub miniature D-connector) to work with this port.

In the PC-Software you must adjust some parameters like the baud rate (19,2 / 38,4 57,6 or 115,2kBaud) and the connected COM-PORT (COM1 or COM2) and the used adapter as 'PC-Adapter'. The PLC-Programmingapplication PG95/PG-2000 or S7-for-Windows wotks the MPI- II - Cable with up to 115,2kBaud on the PC-Side. For the S7-Original-software is an additional driver is needed for the higher baudrates 57.6 and 115.2 kBaud.

2.6 Display and Keyboard of the MPI-II Cable

After Reset the Display shows all relevant Data of the PLC-Connection.

Example of a display:

```
#02PD00
!02AG04
```

In the first line there are displayed from left to right the following Information:

1.) A Sharp „#“ with the number of connected active stations on the MPI-Bus (in this example 2)

2.) The PC-Baud rate

P?	Baudrate-selection+Access path active
T?	Baudrate-selection+Access path active (Cable configured as TS-Adapter)
PU	USB Connection
PD	115,2k or automatic Baudrate-Selection active
TD	115,2k or automatic Baudrate-Selection active (Cable is configured as TS-Adapter)
PG	19,2k
TS	19,2k (Cable is configured as TS-Adapter)
Pg	38,4k
Ts	38,4k (Cable is configured as TS-Adapter)
pG	57,6k
tS	57,6k (Cable is configured as TS-Adapter)

Handbook Cable & Adapter

3.) The station-number of MPI – II Cable (In S7-Manager under „Extras / PG/PC-Interface“ with “Properties/Net/locale station number“). The default is 0.

4.) When communicating a tiled bar (top is to PLC, bottom is PD)

In the second line there are display from left to right the following information:

1.) An ampersand „!“ if connected directly to a PLC or a question-mark „?“ if not directly connected. They are displayed negated on passive Stations which are not in the Token-Ring.

2.) The station-numbers of all active and connected stations in the MPI-Bus. Every $\frac{3}{4}$ second another station is displayed.

3.) The Protocol-Type which is used between Cable and PC:

AG unknown, because no communication or
 Before-V5.0 Protocols

Ag V5.1-Protocols





ag V5.0-Protocols

4.) The PLC which is momentarily is connected to the PC-Software (in our example is the Station 4 connected).

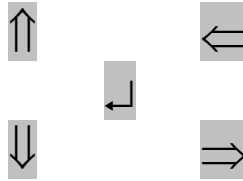
2.6.1 The Keyboard

The keyboard on the back of the cable is used for navigating through menus and for configuring the cable. There are the following keys sensing and colored:



	Confirm the input. Saves the configuration permanently into the flash-memory. Change into a menu or menu-point	ENTER
	Increasing a value, selecting a menu-point	UP
	Decreasing a value, selecting a menu-point	DOWN
	Cancellation of a input/selection, the selection is not saved, one menu-level back	LEFT
	Go into a sub-menu	RIGHT

2.6.2 Main Menu

You select the main-menu with ENTER, with ENTER again you reactivate the default-display. On the Main-menu you could also select the default-display with LEFT.

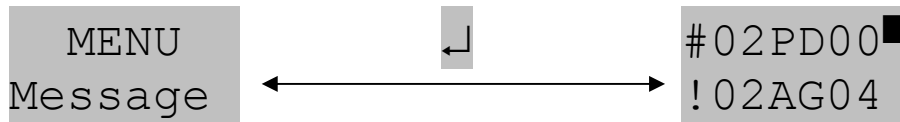

With UP/DOWN you could choose the following menu-points:

Message	activate default-display
Info	Information over the MPI-II cable
Bus	MPI-Bus information's
Config	Configuration of the cable

2.6.3 Info

With RIGHT or ENTER you select the following sub-menu, which has momentarily only one element::

```
Info
Version
```

With LEFT you will leaving this sub-menu to the main-menu. With ENTER you will enter the submenu.

2.6.3.1 Version

With RIGHT or ENTER you will enter the following display, which will display the actual operation system version of the cable:

```
Version
1.52
```

With LEFT or ENTER you will leave this sub-menu-point to the menu info.

2.6.4 Bus

With RIGHT or ENTER you enter the following sub-menu which has only one element:

```
Bus
Address
```

With LEFT you leave this sub-menu to the main-menu. With ENTER you enter the sub-menu.

2.6.4.1 Adressen

With RIGHT or ENTER you enter the following display, which shows the connected stations on the MPI-Bus:

```
Adressen
D 018
```

With UP or DOWN you browse the addresses, where in the second line the following chars are possible:

D	The MPI-II Cable is connected directly to this station
A	This station is active in the BUS
P	This station is passive like for example some OP's, FM or Profibus-Slaves.

Handbook Cable & Adapter

With LEFT or ENTER you leave this sub-menu to the menu info.

2.6.5 Config

With RIGHT or ENTER you enter the following sub-menu where you could select the following sub-menus:

```
Config
Mode
```

With UP/DOWN you could choose the following sub-menus:

Mode	For selecting the function of the Cable.
Data	locks configuration
MPI -BUS	Configuration of the MPI-Parameter
PG/PC	Configuration of the PC-Parameter
Protocol	PC-seitiges Protokoll einstellen
Language	Selection of the Menu-Language
Set Def.	the Default-Properties are loaded. The User-Configuration is erased
Password	input Systempassword

With LEFT you leave this sub-menu to the main-menu. With ENTER you enter the sub-menu.

2.6.5.1 Mode

With RIGHT or ENTER you enter the following sub-menu where you could select following menu-points::

```
Mode
MPI
```

With UP/DOWN you select the following menu-points:

MPI SER	The Cable works in a MPI-Bus Over a serial RS232
MPI USB	The Cable works in a MPI-Bus Over an USB-Port
PPI 9K6	The Cable is connected to a S7-200 with 9.6kBaud.
PPI 19K2	The Cable is connected to a S7-200 with 19.2kBaud.
PPIUSB96	The Cable is connected to a S7-200 with 9.6kBaud and is used over the USB-Port of the PC
PPIUSB19	The Cable is connected to a S7-200 with 19.2kBaud and is used over the USB-Port of the PC

With LEFT you will leave this sub-menu to the menu mode.

2.6.5.2 *USBStrom*

If you connect the Cable to an USB-Port, the PC reads how much current is used over the USB-Port. With this Menu-point you could change the current

With RIGHT or ENTER you enter the following sub-menu where you could select following menu-points::

```
USBStrom  
000 mA
```

With UP/DOWN you select the following menu-points:

- 000 mA Default-value for a MPI-II Cable with serial and USB-Port. The Cable is powered from the PLC.
- 360 mA Default for a MPI-USB Cable which has only a USB-Port. The Power is used from the USB-Port.

Handbook Cable & Adapter

Some PC's are blocking the Device-driver if the Hub could not power the cable.

2.6.5.3 *Data*

With RIGHT or ENTER you enter the following sub-menu where you could select following menu-points::

```
Data  
locked
```

With UP/DOWN you select the following menu-points:

- | | |
|----------|--|
| unlocked | This is the default, the PC overwrites the settings in Menu-point „Config/MPI-BUS“ (HSA, loc.Stationaddress, Baudrate) |
| locked | The settings from PC are ignored, the settings done in „Config/MPI-BUS“ are used (HSA, loc.Stationaddress, Baudrate) |

2.6.5.4 *MPI-BUS*

With RIGHT or ENTER you enter the following sub-menu, in which you could choose following sub-menus:

```
MPI/PPI  
Baudrate
```

With UP/DOWN you could enter the following sub-menus:

- | | |
|----------|--|
| Baudrate | MPI-Baud rate configuration, the baud rate selected here is used, even when another is selected over the PG/PC on connection to PLC. |
| HSA | select highest station address |
| local Nr | select local stations address for the cable |

with LEFT you leave this sub-menu to the menu config. With ENTER you enter the sub-menu.

2.6.5.4.1 Baudrate

With RIGHT or ENTER you enter the following sub-menu:

```
MPI-Baud
187.5k
```

With UP/DOWN you could choose between the following baud rates. With ENTER the baud rate is selected:

12M	6M	3M
1.5M	500k	187.5k
93.75k	45.45k	19.2k

„from PC“ The Configuration is transferred from the PC, the Auto-Baudrate search at power-on is **not** executed. If no setting is transferred from pc the standard-baudrate 187K5 is used.

„Auto“ The Auto-baudrate search at power-on is executed **and** the settings are used from PC. The PC overwrites the settings of the auto-baudrate search. If the MPI-Bus is “worse” (Parity-error) this function could not detect the baudrate, in this case the standard-baudrate 187K5 is used. To search baudrates there must at least one other active Station in the MPI-BUS.

With LEFT (Cancel) or ENTER (Select) you leave the sub-menu to the menu MPI.

Handbook Cable & Adapter

2.6.5.4.2 HSA

With RIGHT or ENTER you enter the sub-menu:

```
HSA  
31
```

With UP/DOWN you could choose between the following values, with ENTER you select the value:

126 63 31 15

With LEFT or ENTER you leave this sub-menu to the menu MPI.

2.6.5.4.3 local Nr

With RIGHT or ENTER you enter the following Sub-Menu:

```
localeNo  
0A
```

With UP/DOWN the local station number is increased/decreased with one. With RIGTH/LEFT the station number is increased/decreased by 16. The local station number is displayed in hexadecimal.

With ENTER you leave this sub-menu to the menu MPI.

2.6.5.5 PG/PC

With RIGHT or ENTER you enter the following sub-menu:

```
PG/PG  
Zugriff
```

With UP/DOWN you could select the following sub-menus:

Baudrate configure the communication-baud rate to the PC.

With LEFT you leave this sub-menu to the menu config.
With ENTER you enter the selected sub-menu.

2.6.5.5.1 Baudrate

With RIGHT or ENTER you enter the following sub-menu:

```
PG-Baud
 19.2k
```

With UP/DOWN you could choose the following selections, with ENTER you choose the selection:

```
115.2k  57.6k   38.4k   19.2k
 9.6k    4800     2400    others
```

At menu-point others the baud rate could be selected in 50Baud, normally not used.

With LEFT or ENTER you leave this sub-menu to PG/PC.

2.6.5.6 Protocol

With RIGHT or ENTER you enter the following sub-menu:

```
Protocol
  Auto
```

Handbook Cable & Adapter

With UP/DOWN you could choose the following selections, with ENTER you choose the selection:

Auto	This is the default. The protocol-type is detected and used automatically from the cable (from S7 V5.0ff on faster protocols could be used)
V5.1	Always uses protocol-type V5.1
V5.0 Alt	Always uses protocol-type V5.0

2.6.5.7 Language

With RIGHT or ENTER you enter the following sub-menu:

```
Language
German
```

With UP/DOWN you could select the following languages:

German	Language of menu is German
English	Language of menu is English

With LEFT you leave this Sub-Menu to the Menu config. With ENTER you choose the language and the sub-menu is leaved to config.

2.6.5.8 in Flash

The configuration is saved permanently in the OnBoard-Flash. The following configuration-data is saved:

```
MPI-Baudrate
Language
```

2.6.5.9 *Set Def.*

The default-configuration is saved to OnBoard-Flash without question.

2.7 Software-Installation for USB

Connect the MPI-II-cable with a type-A to A USB-cable with the PC.

Insert the delivered Demo-CD in the CD-ROM-drive and Start the installation of the „PLC - VCom“. (For a detailed description of the PLC – VCom application please read the “Cable and adapter manual” chapter 5.0 PLC-VCom).

2.7.1 Siemens-S7 / PG-2000

At the Installation of the USB-Driver a new virtual COM-Port is inserted in the system, which could be used from several applications.

Choose in the corresponding Property-Dialog this new inserted COM-Port to access over USB to the MPI.

2.8 Technical data

Description	Technical specifications
Dimensions without cables	146 x 41x 29mm (l x w x h)
Case type	ABS, V0,
Cable type	UL2464, 28AWG, double shielded
Interfaces To the MPI-BUS To the PG/PC	RS485 (187,5 kbaud) RS232 19,2 kbaud or 38,4 kbaud 115 kBaud with PG95 USB 1.0 with type A to A-cable
Supply voltage	DC 24V +/- 20% The 24V will be taken out of the connected PLC or of the connected adapter.
Power disurpation	Typ. I = 100mA at 24V (5V input not used)
Output current 5V	This 5V output doesn't drive any load and have a 100R resistor in his series. Use it only as bus termination.
Type of protection	IP20
Galv. decoupling	The internal electronic (and RS232) to the bus driver and also to the 24V input are decoupled. The shield from the MPI/PPI side to the RS232 side are connected through

Order Description

MPI-II-Cable 3m	Order.No. 9352
MPI-II-Cable 5m	Order.No. 9352.05m
MPI-II-Cable 10m	Order.No. 9352.10m
MPI-II-Cable 15m	Order.No. 9352.15m
Power supply for MPI-Cable	Order.No. 9350-4
Interface cable 9pin to modem	Order.No. 9350-TS
T-connector to MPI / PPI - Bus	Order.No. 9361-7
USB cable type A to A	Order.No. 9352.1

3 S5ToMPI

3.1 Functional-Description

The S5ToMPI-Cable inter-connects a S5 to a S7-PLC for DataBlock-Exchange .

The PLC controls this function. In one or both PLC's a Communication-DB is needed, in which the Source- and Destination-Datablocks are defined. The data is transferred as possible as can. This function is compatible to the SPS-Option by the TeleLink (same structure).

The S5ToMPI-Cable has (except the bridge-function) the same technical-structure as the MPI-II Cable, so this description outlines only the changes to the MPI-II Cable. Usage, menu and technical datasheet could be re-read at chapter 2.

3.2 Connecting the Interface

The S5ToMPI-Cable is connected to the S7-PLC with the short end, the longer side is connected to a TTY-RS232 Converter. Take care that both sides have the same ground potential. Connect the following pins as minimum on RS232:

Pin	Description
2	Transmit Data from S5anMPI-Cable to a TTY-RS232 Converter
3	Recieve Data from TTY-RS232 Converter to the S5anMPI-Cable
5	Ground

The further configuration is done by keyboard on the cable.

3.3 Configuration on the Cable

Press the Key ENTER to display the main menu. With Cursor UP the menu is changed to „Config“, press ENTER to go into the Sub-Menu „Config“. Select with UP/DOWN the menupoint „S5toMPI“, all other Sub-Menu entries reacts in the same way as described in chapter 2.

Pressing RIGHT or ENTER the following submenu is displayed, in which you could choose between the following menu-points:

```
S5toMPI
  Mode
```

Pressing UP/DOWN you could choose between the following menu-points:

Mode	Switch the mode ON/OFF
S7Config	Configuration of S7-MPI Side
S5Config	Configuration of S5-MPI Side

With LEFT the submenu is leaved and switched to the menu Config. With ENTER the menupoint is chosen.

3.3.1 Mode

Pressing RIGHT or ENTER the following submenu is displayed, in which you could choose between the following menu-points:

```
Mode
  OFF
```

Pressing UP/DOWN you could choose between the following menu-points:

OFF	The S5ToMPI-Kabel works as MPI-II Cable (no Bridge-function)
S5 -> S7	The S5-PLC is controlling the transferred Data-Blocks in the communication-DB
S7 -> S5	The S7-PLC is controlling the transferred Data-Blocks in the communication-DB
S5 < > S7	both PLC's S5 and S7 are controlling the transferred Data-Blocks in the communication-DB

With LEFT the sub-menu is leaved to the menu „S5toMPI“. With ENTER this selection is saved to Flash-Memory. After Resetting the Cable the function is activated and the polling of the SPSFlags is started (see further).

It is a good idea to select the mode as last.

3.3.2 S7Config

By pressing ENTER or RIGHT the following submenu appears:

```
S7Config
CPU
```

By pressing UP/DOWN you can choose the following options:

CPU	Settings of the station-number of the S7 with which will be communicated.
MPI Bus	Configuration of the MPI-bus.
SPSFlags	Configuration of the command/statusflag
CommDB	Configuration of the Communications-DBs

Handbook Cable & Adapter

With the key LEFT you will leave this submenu. Using ENTER jumps into the menu.

3.3.2.1 CPU

With the keys RIGHT or ENTER the following menu appears on the LCD:

```
S7 CPU
StatNumb
```

By pressing UP/DOWN you can choose the following options:

StatNumb	Configuration of the station number of the S7
Slot	Slot configuration of the S7CPU
Function	Define functions number

Using the key LEFT leaves this menu, using the keys ENTER or RIGHT jumps to the selected menu-

3.3.2.1.1 StatNumr

By pressing RIGHT or ENTER, the following submenu appears on the LCD:

```
StatNumb
 002
```

By pressing UP/DOWN the station number will be incremented/decremented by one. The station number is displayed as a 3 character-wide value and can take the values between 000 and 126. Default value is 2.

With ENTER you can confirm your changes, LEFT will discard them.

3.3.2.1.2 SlotNr

By pressing RIGHT or ENTER the following menu appears:

```
SlotNo
  00
```

By pressing UP/DOWN, the number of the slot will be increased/decreased by one. The slot number is displayed as a 2 character-wide number and can take values between 00 and 31. Default value is 0. (some double-width CPU cards need the slot number set to 3).

Using ENTER confirms your changes, LEFT discards them.

3.3.2.1.3 Function

By pressing RIGHT or ENTER the following menu appears on the LCD:

```
Function
  03
```

By pressing UP/DOWN the function number will be increased/decreased by one. The function number is displayed as a 2 character-wide, decimal number, which can take the values between 00 and 03. Default value is 03. This setting has to be changed only in special cases. The default setting is working for most cases.

Function	Description
1	PG/PC
2	OP/Operator Panel, HMI
3	Step7 Basiscommunication

Pressing ENTER saves your changes, LEFT will discard them.

3.3.2.2 *MPI Bus*

By pressing ENTER or RIGHT the following menu appears:

```
MPI-Bus  
Address
```

By pressing UP/DOWN you can choose the following options:

Address	local station address of the S5ToMPI-cable
Profil	configure the time-profile of the MPI/DP-Bus

3.3.2.2.1 Address

With the keys ENTER or RIGHT you can configure the following option:

```
Address  
 01
```

By pressing UP/DOWN the address will be increased/decreased by one. The address is displayed as a 3 character-wide number and can take a values between 000 and 127. Default setting is 001. This is the **station number of the cable**.

ENTER saves your changes, LEFT discards them.

3.3.2.2.2 Profile

With the keys RIGHT or ENTER the following menu appears:

```
Profil
MPI
```

By pressing the the keys UP/DOWN you can choose the following options:

MPI	MPI-Bus
DP	Profibus, Profile DP
UNI	Profibus, Profile Universell (DP/FMS)
Standard	Profibus, Profile Standard

Confirm you changes with ENTER, discard them with LEFT.

3.3.2.3 *SPSFlag*

Pressing ENTER or RIGHT, the following menu appears on the LCD:

```
SPSFlag
MW000254
```

By pressing UP/DOWN the address will be increased/decreased by one. The address is displayed as a 6 character-wide, decimal number which can takes a value 00000 and 65534. Default setting is 000254. This is the command and status flag. The flag must be an even number.

Confirm you changes with ENTER or leave the menu by pressing LEFT.

Handbook Cable & Adapter

3.3.2.4 *Comm DB*

By pressing ENTER or RIGHT the following menu appears:

```
Comm DB
DB    000
```

By pressing UP/DOWN the datablocknumber of the communications-datablock will be increased/decreased by one. It is displayed as a 6 character-wide, decimal number which can take the values between 00000 and 65534. Default setting is 000254.

Confirm your changes with ENTER or discard them with LEFT.

3.3.3 **S5Konfig**

With ENTER or RIGHT the following menu appears:

```
S5Config
S5 CPU
```

By pressing UP/DOWN the following options can be configured:

S5 CPU	Settings of the S5 with which will be communicated.
SPSFlag	Configuration of the command/status flag
CommDB	Configuration of the communications-DBs

Confirm your changes by pressing ENTER, discard them with LEFT.

3.3.3.1 CPU

With ENTER or RIGHT the following menu appears:

```
S5 CPU  
Slave 00
```

By pressing UP/DOWN the S5-CPU number will be increased/decreased by one. If the CPU-number is equal to 0, the S5 will be accessed directly. If you set the CPU-number to a value between 1 and 30, the connection will be established over the path of the PG.

The CPU-number is displayed as a 2 character-wide decimal number and can take a value between 00 and 30. Default setting is 00.

Confirm your changes with ENTER, discard them with LEFT.

3.3.3.2 SPSFlag

Pressing ENTER jumps to the following menu:

```
SPSFlag  
MW 254
```

By pressing UP/DOWN the address will be increased/decreased by one. The address is displayed as a 3 character-wide decimal number and can take a value between 000 and 254. Default value is 000254. This is the command and status flag. Only even flags are allowed.

Confirm your changes with ENTER, discard them with LEFT.

3.3.3.3 Comm DB

By pressing ENTER or RIGHT the following menu appears:

```
Comm DB  
DB 000
```

By pressing UP/DOWN the datablocknumber of the communication-datablock will be increased/decreased by one. It is displayed as a 3 character-wide, decimal number and can take a value between 000 and 254. Default setting is 000254.

Confirm your changes with ENTER, discard them with LEFT.

3.4 The Display

3.4.1 Display

If the device's power is on, all relevant parameters of the S5toMPI-cabel will be displayed.

Example of a display:

```
S500S708  
010S>010
```

The first line displays the following information:

- 1.) „S5“ followed by a 2 character-wide, decimal CPU number (00=direct connected S5,1..30=S5 connected via a 4 wire line)
- 2.) „S7“ mit nachfolgender 2stelliger, dezimaler Stationsnummer

The second line displays the following information: (from left to right)

- 1.) 3 character-wide, decimal: the last used datablock-number of the S5.
- 2.) ID character of what action is performed at the moment:
 - S> send-command from S5 to the S7
 - F< fetch-command from S5 to the S7
 - <S send-command from S7 to the S5
 - >F fetch-command of the S7 from the S5
 - empty action performed
- 2.) 3 character-wide, decimal: the last used datablocknumber on the S7.

3.4.2 Error messages

In the case of an error, additional information will be displayed in the lower line of the LCD.

(Also the error is logged in the status byte of the SPS-Flag)

Example of a display:

```
S500S708
Q010F5Er
```

Display	comments
? AG	There is no fetch- or send-query in the command-byte.
MWS5noRD	Could not read SPS-flag from the S5
MWS7noRD	Could not read SPS-flag from the S7
K<DBNr>S5Er	Communication-DB <DBNr> in the S5 not available or too short
K<DBNr>S7Er	Communications-DB <DBNr> in the S7 not available or too short
S5ParmEr	Parameter error in the communications-DB of the

Handbook Cable & Adapter

	S5, could not execute command
S7ParmEr	Parameter error in the communications-DB of the S7, could not execute command
Q<DBNr>S5Er	Could not execute send command from the S5: the source-DB <DBNr> in the S5 is not available or too short.
Q<DBNr>S7Er	Could not execute send command from the S5: the source-DB <DBNr> in the S7 is not available or too short
Z<DBNr>S5Er	Could not execute send command of the S5: ist the destination-DB <DBNr> int the S7 is not available or too short.
Z<DBNr>S7Er	Could not execute send command of the S7: the destination-DB <DBNr> in the S5 is not available or too short.
Q<DBNr>F5Er	Could not execute fetch-command from the S5: the source-DB <DBNr> of the S7 is not available or too short
Q<DBNr>F7Er	Could not execute fetch command from the S7: the source-DB <DBNr> of the S5 is not available or too short
Z<DBNr>F5Er	Could not execute fetch command from the S5: the destination-DB <DBNr> of the S5 is not available or too short
Z<DBNr>F7Er	Could not execute fetch-commandBfrom the S7: the destination-DB <DBNr> of the S7 is not available or too short.

3.5 SPS-Flag

The communication between the S5 and S7 is controlled with the SPS-Flag. Also useful status information is returned via the SPS-Flag. The SPS-flag must be set to an even value. The higher byte of the word is the command-byte the lower byte displays the status

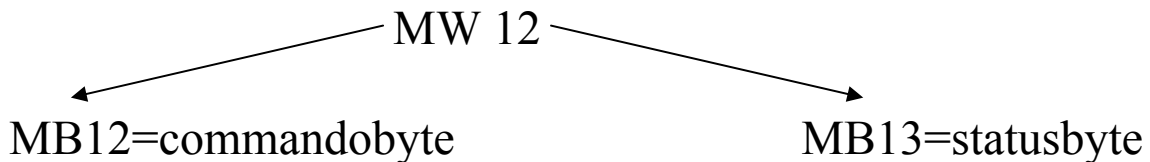

3.5.1 the commandbyte

With this byte the direction of data is controlled.

- 00h = no command will be executed
- 01h = send-command: The source-block will be written to the destination-block of the remote station
- 02h = fetch-command: The source-block will be read from the remote station and transferred to a datablock of this plc.
- 04h = Do a Reset of the cable

All other values are not defined and not allowed. The command will only executed if the status byte is 00h.

3.5.2 the status byte

This byte displays the status of the transfer from the S5ToMPI cable.

To start the next transmission, this byte must be set to 00h from the PLC as acknowledge.

- 00h = start of transmission, S5ToMPI-Cable has not yet recognized the start or acknowledge last transfer.
- 01h = transmission successfully executed
- 02h = transmitting data, you have to check for TIMEOUT, the transfer should be executed after 45 seconds
- 03h = the source-datablock is not available or too short
- 04h = the destination-datablock is not available or too short
- 05h = general fault, retry command
- 06h = communication-DB not available or too short
- 07h = parameter error in communication-DB
- 08h = No answer from remote PLC

3.6 the communications-data block

If the command-byte is detected correctly, the configured communications-datablock will be read from the station.

The structure of this data block is for the S7:

Address	Format	Comment
000	CHAR	2 characters sourcetype ,DB'
001	CHAR	
002	UINT	Source-datablocknumber
004	UINT	Begin word
006	UINT	Length in words
008	CHAR	2 characters destinationtype ,DB'
009	CHAR	
010	UINT	Destination-datablocknumber
012	UINT	Begin word
014	UINT	Length in words

The structure of this data block is for the S5:

Address	Format	Comment
000	KC	2 characters sourcetype ,DB'
001	KF	Source-datablocknumber
002	KF	Begin word
003	KF	Length in words
004	KC	2 characters destinationtype ,DB'
005	KF	Destination-datablocknumber
006	KF	Begin word
007	KF	Length in words

- Source/Destinationtype = Only ,DB' is allowed at the moment, so only datablocks will be transfered (no DX at S5!)
- Source/DestinationDB = At S5 DB between 001 and 255 allowed
At S7 DB between 00001 and 65534 allowed
- BeginDW = At S5 DW between 000 and DW 254 allowed
At S7 DW between 00001 and 65534 allowed
- Length = maximum: 256 words, no 0 Allowed. Both lengths have to be the same

In case of an error, the error code 07h –parameter error- will be displayed in the status byte.

Please keep in mind, that changing the communication-DB in S7 eventually not changes the values. Look in the „Data-view” of the DB. Declaration and Data-View could have different values, which could lead to wrong or faulty behavior.!

4 MPI-USB

4.1 functional description

The MPI-USB-cable connects the Programming Device or the PC over a USB 1.1 interface with the MPI or DP/FMS-Interface of a S7-300/400. With the software “PLC-VCom” it is possible to access the stations on the MPI-bus with S7-Original or any other programming software.

On the MPI-side it is possible to set baud rates between 19K2 and 12MBaud, but please keep in mind that the MPI-baud rates 3M,6M and 12Mbaud can be configured only at the cable. Also the cable can detect the baud rates on the MPI-bus automatically.

The MPI-USB-cable gets its power from the USB-interface and normally needs no other power source. Optionally the cable can be powered via a external power input. All electronics are galvanic decoupled (24V input to the bus and the internal power supply).

4.2 MPI-USB as HMI-Adapter

HMI (Human Machine Interface):

The HMI-Function allows the connection of a operating terminal (which has no internal MPI-bus, but uses the HMI-Protocol and a USB-interface) to a S7-300/400. The cable has to be connected to the operating terminal and the PLC. The HMI-protocol must be implemented in the operating terminal.

4.3 Pinning

4.3.1 Pinning USB (PC-side)

pinnr.	shortform	Comment	direction (cable-view)
1	Vcc	Power supply	Input
2	D-	Data line -	Input & Output
3	D+	Data line +	Input & Output
4	GND	Ground	Input

Note:

At Vcc a maximum of 400mA can be taken.

Important:

Please do not lengthen this side, this side also leads 5V power supply (maximum cable length are 10m).

A longer cable would decrease the quality of the signal on the bus and therefore lead to severe errors in the transmission !

4.3.2 Pinning MPI (PLC-Side)

pinnr.	shortform	Comment	direction (cable-view)
1	NC	Not connected	
2	M24V	Ground 24V	Input
3	Ltg_B	Data line B	Input & Output
4	RTS-AS	Ready-to-Send from AS	Input
5	M5V	Ground 5V	Input
6	P5V	5V Output	Output
7	P24V	24V Input	Input
8	Ltg_A	Data line A	Input & Output
9	RTS-PG	Ready-to-Send to AS	Output
shield		At both SUB-D cases	

Handbook Cable & Adapter

Note:

The SUB-D plug is shielded. The RTS-AS and M5V must lie on this shield to detect direct stations. P5V is a output of the cable and is needed for bus terminating reasons. These 5V are not usable and secured with a 100R resistor.

Important:

Do not lengthen this side. This side leads both 24V and 5V. This would decrease the quality of signals on the bus !

To lengthen the MPI – USB cable, please supply the cable externally with 24V power, and lengthen only signals line_A und line_B 1:1. Be sure to put the shield on the SUB-D plug. Also be sure to use terminating resistors where applicable (at the bus ends).

4.3.3 External powersupply



Signalname	shortform	In/Out (cable-view)	Pinnr.
24V supply	P24V	In	1
Ground 24V	M24V	In	2

Connecting the adapter

The short side of the cable has to be connected to the MPI- bzw. PPI-Interface of the PLC Go into a sub-menu. The MPI-USB-cable gets its power from the USB and does not need an external power source. The longer side of the cable has to be plugged in the USB-port of the PG or the PC.

For the connection over USB a type A to type A USB cable is needed.

As the cable is plugged in the USB port, it displays its software version and performs a power-on-self-test. The display shows all relevant information of the MPI-USB cable-

The software „PLC - VCom“, which is included with your cable, installs a “virtual” com-port in your system. So your programming software has to be set to this comport when using the MPI-USB cable. For further information please refer to the section “PLC - VCom” in this manual. Otherwise use the detailed description in chapter 5.0 PLC – VCom of the “Cable and adapter manual”.

4.4 Display and Keyboard of the MPI-USB cable

The displays shows all important information of the of the MPI-USB cable:

Example of a display:

```
#02PU00  
!02AG04
```

The first line displays the following information from left to right

1.) A hash „#“ followed by the number of active, detected stations on the MPI-bus (in this example 2)

2.) The PC-baud rate:

P?	baud rate detection+accesspath active
PU	USB connection

3.) The station number of the MPI-USB cable when accessing the bus. (you can change it in the S7-Manager in the menu „Options → SetPG/PCInterface → Properties → local connections → address“). Default value is 0.

4.) When data is transferred to the PLC, a black cursor will be displayed in the upper right corner of the lcd. When data is transferred to the PC, the black cursor will be displayed in the lower right corner.

In the second line of the display, the following information is displayed:

1.) An exclamation mark „!“ when directly connected to the PLC ore a question mark „?“ when not directly connected to the PLC. These are inverted when using passive stations which are not in the token-ring.

2.) The station numbers of the active stations in the MPI busI. All $\frac{3}{4}$ second another station will be displayed.

3.) The type of protocol from the cable to the pc:

AG unknown, as there was no communication yet, or before V5.0 protocols

Ag V5.1-protocol

ag V5.0-protocol

4.) The station connected to the pc-software at the moment. In our example the station 4.

4.4.1 The keyboard

The keyboard on the back of the cable is needed for navigation through the menu tree. There are the following keys:

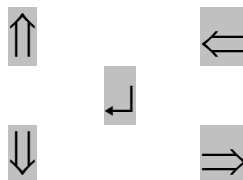

↵	Confirm the input. Saves the configuration permanently into the flash-memory. Change into a menu or menu-point	ENTER
↑↑	Increasing a value, selecting a menu-point	AUF
↓↓	Increasing a value, selecting a menu-point	AB
←←	Cancellation of a input/selection, the selection is not saved, one menu-level back	LINKS
⇒	Go into a sub-menu	RECHTS

4.4.2 Main menu

You can jump to the main menu by pressing ENTER. Pressing ENTER again returns to the standard display. On the Main-menu you could also select the default-display with LEFT.



Because the MPI-USB cable is technical identical to the MPI-II Cable (except that the MPI-USB has no RS232 Interface), the functions of the menu are described in chapter 2.

4.5 Installation of the software for the MPI-USB cable

Put the Demo-CD, which came with your cable, in your CD-Rom drive and start the installation of "PLC - VCom". (For a detailed description of the PLC – VCom application please read the "Cable and adapter manual" chapter 5.0 PLC-VCom).

4.5.1 Siemens-S7 / PG-2000

With the installation of PLC-VCom a additional, virtual com-port will be installed in your system. With it, you are able to use the cable within your programming software.

For further information refer to the section "PLC - VCom" in this manual. Otherwise read the chapter 5.0 PLC – VCom of the "Cable and adapter manual" for a detailed description.

4.6 Technical data

Description	Technical specifications
Dimensions without cables	146 x 41x 29mm (l x w x h)
Case type	ABS, V0
Cable type	UL2464, 28AWG, double shielded
Interfaces To the MPI-BUS To the PG/PC	RS485 (19,2/93,5/187,5/500kBaud 1.5/3/6/12Mbaud) USB 1.0 Type A-A cable
Supply voltage	DC 24V +/- 20% The 24V will be taken out of the connected PLC or of the connected adapter.
Power disurpation	Typ. I = 360mA at 5V
Output current 5V	This 5V output doesn't drive any load and have a 100R resistor in his series. Use it only as bus termination.
Type of protection	IP20
Galv. decoupling	The internal electronic to the bus driver and also to the 24V input are decoupled. The shield from the MPI/PPI side to the USB side are connected through

Ordering

MPI – USB – Cable 3m
 MPI – USB – Cable 5m
 Cheap-Conn (optional)

Ord. No. 9352-USB
 Ord. No. 9352-USB.05m
 Ord. No. 9350-9-CHP

5 MPI-LAN

5.1 Functional description

The MPI-LAN connects your PC with the MPI Interface over a TCP/IP network. Beside the MPI-LAN cable, you need the software „PLC - VCom“ on the PC with the SPS Programming software (such as PG2000). (For a detailed description of the PLC – VCom application please read the “Cable and adapter manual” chapter 5.0 PLC-VCom).

The MPI-LAN cable, connected with a ordinary network card of a PC or a switch, automatically detects the speed of your network (10/100mbit).

The default-IP-Address is 192.168.1.56

If there is a DHCP-Server accessible, an IP-Address is requested from this DHCP-Server!

5.2 Connecting the cable

The MPI-LAN cable will be connected with his short side to the MPI Interface.

The cable works with the current output voltages of the PLC and doesn't need any external voltages. The cable requires a PLC to get the 24V out of it. You can also use an optional power supply to work with an external 24V voltage. So the cable can be lengthened.

The longer side of the cable must be connected with the network interface of your PC or switch.

Connected with a current supplier, the MPI-LAN performs a power-on-self-test. The LCD of the cable is showing all relevant data.

Handbook Cable & Adapter

To establish communication with the PC and the cable, install the software „PLC-VCom“ which came with your cable. (Please refer to the section PLC - VCom).

5.3 Display and keyboard of the MPI-LAN

After Reset the Display shows all relevant Data of the PLC-Connection.

Example for Display:

```
#02PD00 ■  
!02AG04
```

In the first line there are displayed from left to right the following Information:

- 1.) A Sharp „#“ with the number of connected active stations on the MPI-Bus (in this example 2)
- 2.) The PC-Baud rate

PD	115,2k or automatic Baudrate-Selection active
TD	115,2k or automatic Baudrate-Selection active (Cable is configured as TS-Adapter)

PG	19,2k
TS	19,2k (Cable is configured as TS-Adapter)

Pg	38,4k
Ts	38,4k (Cable is configured as TS-Adapter)

pG	57,6k
tS	57,6k (Cable is configured as TS-Adapter)

3.) The station-number of MPI – II Cable (In S7-Manager under „Extras / PG/PC-Interface“ with “Properties/Net/locale station number“). The default is 0.

4.) When communicating a tiled bar (top is to PLC, bottom to PG)

In the second line there are display from left to right the following information:

1.) An ampersand „!“ if connected directly to a PLC or a question-mark „?“ if not directly connected.

2.) The station-numbers of all active and connected stations in the MPI-Bus. Every $\frac{3}{4}$ second another station is displayed.





3.) static Text „AG“ (means PLC)

3.) The PLC which is momentarily is connected to the PC-Software (in our example is the Station 4 connected).

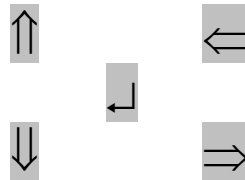
5.3.1 The Keyboard

The keyboard on the back of the cable is used for navigating through menus and for configuring the cable. There are the following keys sensing and colored:



	Confirm the input. Saves the configuration permanently into the flash-memory. change into a menu or menu-point	ENTER
	Increasing a value, selecting a menu-point	UP
	Decreasing a value, selecting a menu-point	DOWN
	Cancellation of a input/selection, the selection is not saved, one menu-level back	LEFT
	Go into a sub-menu	RIGHT

5.3.2 Main menu

You select the main-menu with ENTER, with ENTER again you reactivate the default-display. On the Main-menu you could also select the default-display with LEFT.

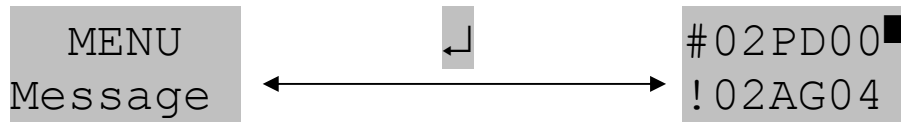

With UP/DOWN you could choose the following menu-points:

Message	activate default-display
Info	Information over the MPI-II cable
Bus	MPI-Bus information's
Config	Configuration of the cable

5.3.3 Info

With RIGHT or ENTER you select the following sub-menu, which has momentarily only one element::

```
Info
Version
```

With LEFT you will leaving this sub-menu to the main-menu. With ENTER you will enter the submenu.

Handbook Cable & Adapter

5.3.3.1 *Version*

With RIGHT or ENTER you will enter the following display, which will display the actual operation system version of the cable:

```
Version  
1.01
```

With LEFT or ENTER you will leave this sub-menu-point to the menu info.

5.3.4 **Bus**

With RIGHT or ENTER you enter the following sub-menu which has only one element:

```
Bus  
Address
```

With LEFT you leave this sub-menu to the main-menu. With ENTER you enter the sub-menu.

5.3.4.1 Adresses

With RIGHT or ENTER you enter the following display, which shows the connected stations on the MPI-Bus:

```
Adressen
D 018
```

With UP or DOWN you browse the addresses, where in the second line the following chars are possible:

D	The MPI-LAN Cable is connected directly to this station
A	This station is active in the BUS
P	This station is passive like for example some OP's,FM or Profibus-Slaves.

With LEFT or ENTER you leave this sub-menu to the menu info.

5.3.5 Config

With RIGHT or ENTER you enter the following sub-menu where you could select the following sub-menus:

```
Config
Mode
```

With UP/DOWN you could choose the following sub-menus:

Mode	For selecting the function of the Cable.
Protocol	For setting the MPI Protocol
MPI	Configuration of the MPI-Parameter
PG/PC	Configuration of the PC-Parameter
Language	Selection of the Menu-Language
in Flash	Permanently Saves the Configuration
Erase	erases the Configuration, the Default-Properties are loaded
IP-Adr	configure the ip-address of your cable
Password	changing the password of your configuration settings

With LEFT you leave this sub-menu to the main-menu. With ENTER you enter the sub-menu.

5.3.5.1 *Mode*

With RIGHT or ENTER you enter the following sub-menu where you could select following menu-points::

```
Mode
MPI
```

With UP/DOWN you select the following menu-points:

MPI	The cable acts in a MPI-Bus
PPI	The cable is connected to a S7-200

With LEFT you will leave this sub-menu to the menu mode.

5.3.5.2 *MPI*

With RIGHT or ENTER you enter the following sub-menu, in which you could choose following sub-menus:

```
MPI/PPI
Baudrate
```

With UP/DOWN you could enter the following sub-menus:

Baudrate	MPI-Baud rate configuration, the baud rate selected here is used, even when another is selected over the PG/PC on connection to PLC.
HSA	select highest station address
local Nr	select local stations address for the cable

with LEFT you leave this sub-menu to the menu config. With ENTER you enter the sub-menu.

Handbook Cable & Adapter

5.3.5.2.1 Baudrate

With RIGHT or ENTER you enter the following sub-menu:

```
MPI-Baud
187.5k
```

With UP/DOWN you could choose between the following baud rates. With ENTER the baud rate is selected:

```
12M      6M      3M
1.5M     500k    187.5k
93.75k   45.45k  19.2k
```

With LEFT (Cancel) or ENTER (Select) you leave the sub-menu to the menu MPI.

5.3.5.2.2 HSA

With RIGHT or ENTER you enter the sub-menu:

```
HSA
31
```

With UP/DOWN you could choose between the following values, with ENTER you select the value:

```
126      63      31      15
```

With LEFT or ENTER you leave this sub-menu to the menu MPI.

5.3.5.2.3 LocalNr

With RIGHT or ENTER you enter the following Sub-Menu:

```
lokaleNr  
0A
```

With UP/DOWN the local station number is increased/decreased with one. With RIGTH/LEFT the station number is increased/decreased by 16. The local station number is displayed in hexadecimal.

With ENTER you leave this sub-menu to the menu MPI.

5.3.5.3 Language

With RIGHT or ENTER you enter the following sub-menu:

```
Language  
German
```

With UP/DOWN you could select the following languages:

German	Language of menu is German
English	Language of menu is English

With LEFT you leave this Sub-Menu to the Menu config.
With ENTER you choose the language and the sub-menu is leaved to config.

5.3.5.4 *In Flash*

The configuration is saved permanently in the OnBoard-Flash. The following configuration-data is saved:

IP address
MPI-Baudrate
Language

5.3.5.5 *Erase*

The default-configuration is saved to OnBoard-Flash without question.

5.3.5.6 *IP-Adr*

In this menu you can change the IP address of your MPI-LAN cable. Please make sure that the IP-Address given to your cable is unique.

Ask your network administrator to obtain a unique IP address for your network.

Selecting this menu with ENTER/RIGHT, the following screen on the LCD appears:

```
>9<.168.  
001.055
```

With LEFT/RIGHT you can move the cursor (> <). By pressing UP/DOWN you can edit the selected character of the IP address. Confirm your changes with ENTER.

5.3.5.7 Protocol

By selecting this menu with ENTER/RIGHT, you can specify the type of the protocol on the mpi bus. To apply your changes press ENTER, to discard them, use LEFT.

5.3.5.8 Password

Selecting this menu with ENTER/RIGHT, you can edit the password to protect your configuration settings.

By pressing LEFT/RIGHT you can move the cursor, pressing UP/DOWN changes the selected character of the password. Confirm your new password with ENTER.

5.4 Technical data

Description	Technical specifications
Dimensions without cables	146 x 41x 29mm (l x w x h)
Case type	ABS, V0,
Cable type	UL2464, 28AWG, double shielded
Interfaces To the MPI-BUS To the PG/PC	RS485 (187,5 kbaud) RJ45 (10/100Mbit)
Supply voltage	DC 24V +/- 20% The 24V will be taken out of the connected PLC or of the connected adapter.
Power disurpation	Typ. I = 100mA at 24V (5V input not used)
Output current 5V	This 5V output doesn't drive any load and have a 100R resistor in his series. Use it only as bus termination.
Type of protection	IP20
Galv. decoupling	The internal electronic to the bus driver and also to the 24V input are decoupled.

Order Description

MPI-LAN-Cable 3m
LAN

Order.No. 9352-

6 PLC-VCom Application

6.1 Functional Description

The PLC-VCom application is needed for use with the following devices:

- MPI-LAN Cable
- MPI-USB Cable
- MPI-II Cable (USB-mode)
- S5.LAN Cable

It creates a new, virtual com-port in your system, with which the programming software of your PC (such as PG2000) can communicate with the device. **The virtual COM-Port is only view-, select- and accessible when the PLCVCOM is in the „connected“ state, that means a cable is present and usable.**

6.2 Installation of PLC-VCom

Start the installation with the file named „Setup.exe“ of your installation CD.

After you have entered the path and the entry for the start menu, the installation begins.

After the installation has copied the data for the PLC-VCom, you will be asked whether you want to install the USB driver or not.

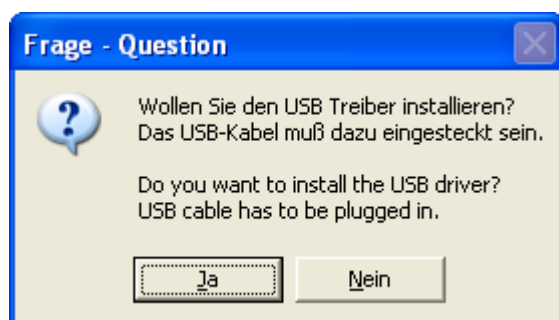

If you don't planning to use any USB devices (e.g. you're using a MPI-LAN Cable), please answer this question with "no".

Handbook Cable & Adapter

If you use a cable with USB support (such as MPI-II, MPI-USB), connect the cable with your PC and choose “yes”.

If you’re working under Windows XP, answer the “Windows XP driver certification”-question with “continue installation”.

After this, you’ll have to select an appropriate com-port for PLC-VCom. Please choose a free com-port of your system, *not used by a physical serial com-port*.

After rebooting your computer, the installation has finished.

6.3 Setting up PLC VCom / using PLC VCom

After installing the software, a small icon in the right lower corner of your windows taskbar appears.

This icon shows the status of the connection with your MPI-II / MPI-USB / MPI-LAN /S5 LAN Cable.

The icon informs you about the following states:



PLC-VCom is not connected with a device.



PLC-VCom has established a connection to a device and is now ready for use.

The icon changes in the case data is sent or received via the virtual com-port of PLC - VCom:



To configure a device, just click on the icon with the left mouse button.

The configuration dialog of the PLC - VCom will be shown:

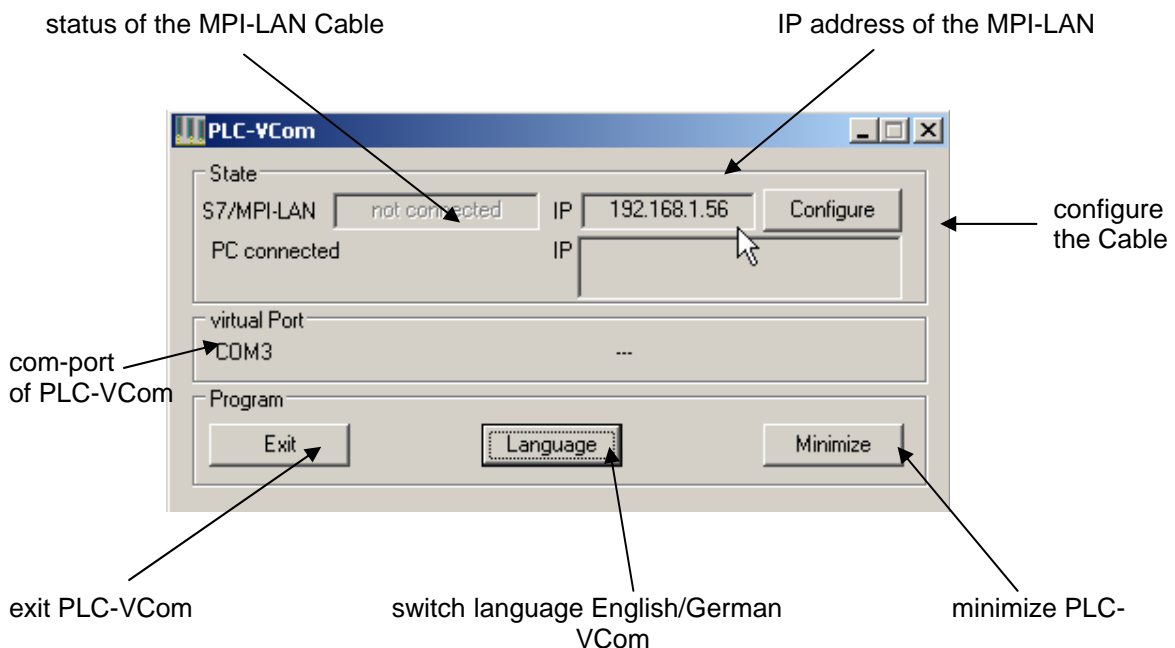

6.3.1 Setting up PLC-VCom for Cables

To set up your Cable, click on the button „configure“. This will start the „LAN IP VCOM Wizard“:

Handbook Cable & Adapter

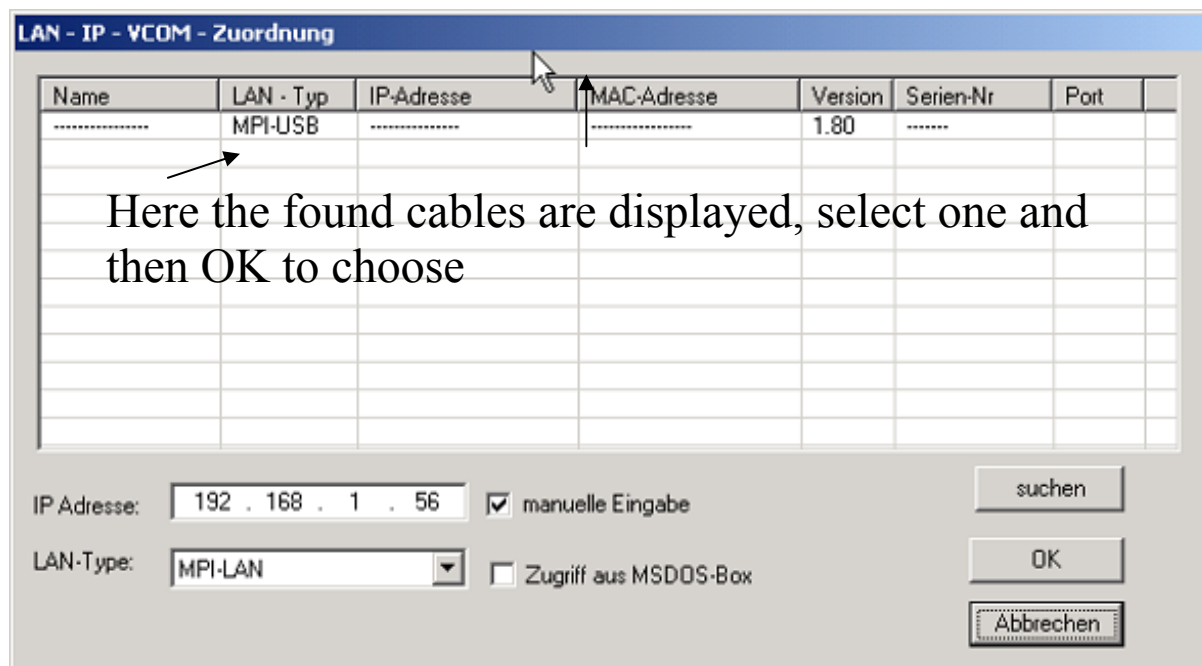

Use the button „search“, to again search all Cables in your network. If you already know the IP address of the MPILAN/S5 - Cable you want to connect, you can enter it in the ip address field by hand.

After confirming your changes with the apply-button, and plugging in the MPI-LAN Cable in your network/PC, PLC-VCom shows the status „connected“. The device can be used (through the com-port entered in PLC-VCom) with your programming software (such as PG2000).

If you have to change the IP address of your MPI-LAN Cable, you can do this by using the function integrated in the MPI-LAN Cable.

Also you can do this by using the software “MPI-LAN Manager”, which came with your cable.

To start the MPI-LAN Manager, click on the appropriate icon in the start menu.

After starting the manager, all reachable MPI-LAN devices in your network will be displayed with information about the cable:

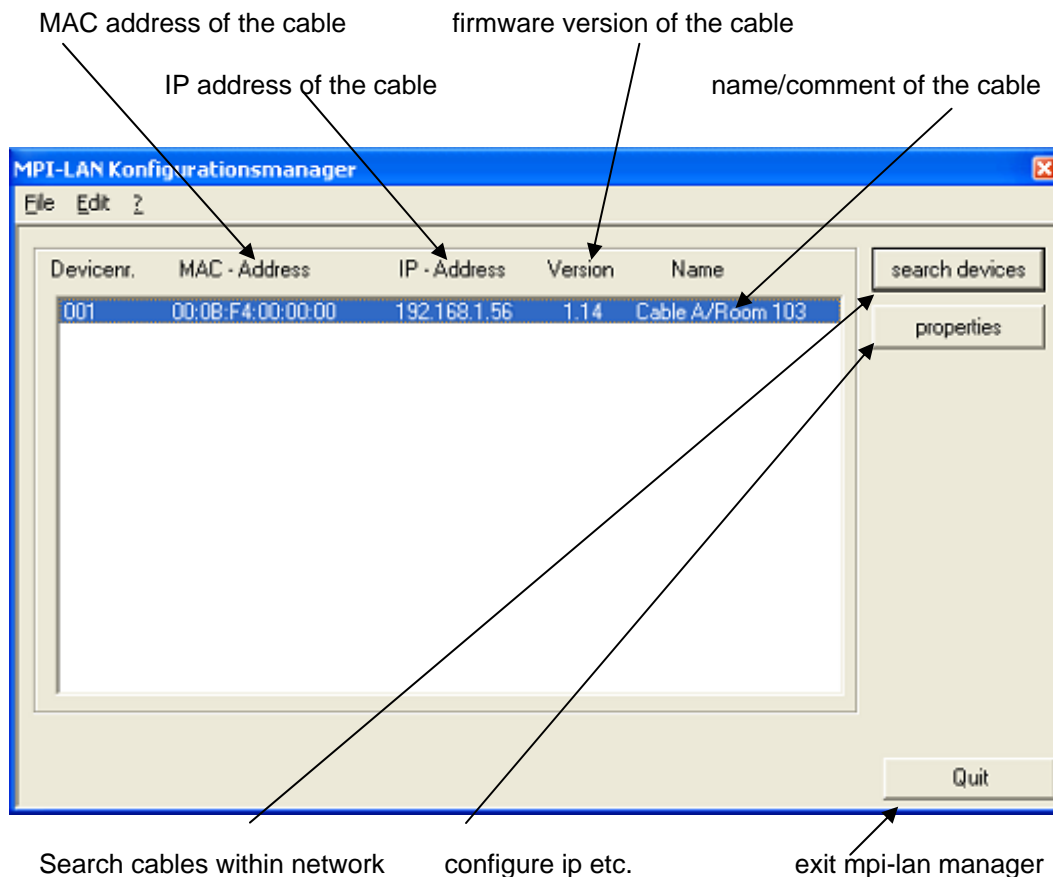

To change the setting of the selected cable, use the button „properties“. A new configuration window will appear and you can set a new ip address for the cable. Also you can give your cable a name, making it easier to find your cable in large networks with many cables.

Important:

Please make sure, that the ip address of your cable is unique within your network.

Also make sure that the pc, with which you want to communicate with the cable, has a valid IP address.

If you're unsure which ip address is suitable for your cable, ask your network administrator.

The virtual COM-Port is only view-, select- and accessible when the PLCVCOM is in the „connected“ state, that means a cable is present and usable.

Handbook Cable & Adapter

7 MPI-Modem

7.1 Description

The MPI-Modem connects the programming device or PC over the serial Interface (COM-Port) or by Modem to the PC over an analog telephone line with the MPI- or DP/FMS-Connector of the S7-300/400 PLC. The MPI-Modem selects automatically on the first access which Port and which Baud rate is used. With our PLC-Programming-Application PG-95/PG-2000 or S7-for-Windows works the MPI-Modem with up to 115.2kBaud on the PC - Side.

On the MPI-Side you could use Baud rates from 19k2 up to 12MBaud.

It is possible use the MPI-Modem on a MPI-Connection with only the 2 Data-Lines.

7.2 MPI-Modem as TS-Adapter

The TS-possibility allows the connection of a modem, to make a connection with a 2nd Modem and a PC to a S7-300/400. The MPI-Modem must be connected to an analoge telephone line and the PLC .

To work with the MPI-Modem in his TS-function, you must make the following actions:

- 1) You need the TeleService-software from Siemens in your PC to work with the MPI-Modem. The configuration of the MPI-Modem can be made with the TeleService-software from Siemens or with the "MPI-Kabel Manager".
- 2) On the PC side you need another modem.

7.3 TeleService Function

First you need to set up the hardware in order to use this function. You need to configure the MPI – Modem and the software you want to use.

7.3.1 Setting up the hardware

For establishing a connection with your PLC by using the standard telephone network you need the MPI - Modem and a standard modem. With this equipment you will be able to get access to your PLC from all over the world*.

*needs to be connected with the telephone network.

Connect the MPI – Modem:

The MPI interface (on the right) of the MPI – Modem has to be connected with the PLC. Connect the telephone cable with the plug (bottom, left) on the modem.

Connect the standard modem:

Connect the telephone cable with the Line-In plug of the standard modem. Do not forget to connect the serial interface with your computer.

For setting up the modem by using Windows you should read the manual from the manufacturer of the modem.

7.3.2 Configure the MPI – Modem

↵ ↑	° MENU ° ° Config °	Enter the menu by pressing ↵ and select the menu „ Config “ with the ↓ ↑ arrows.
↑ ↵	Password ° >0< °	Enter the password (standard is “ 0 ”) and confirm with ↵.
↑ ↵	° Config ° ° PG/PC °	Search for the sub menu “ PG/PC “ and get in with ENTER (↵).
↑ ↵	° PG/PC ° MPI Accs °	In the menu “ PG/PC “ navigate to the configuration point “ MPI Accs “.
↑ ↵	MPI Accs ° ° MODEM °	Set it to “ MODEM ”.
↑	° Modem ° baudrate °	After confirming you will be back in the

↩		“ Config “ menu. From there search to the sub menu “ Modem “ and select “ baudrate “.
↑ ↩	baudrate automatic	Set it to “ automatic “.

The MPI – Modem is prepared for the TeleService Software. The status display (menu “Message”) contains the message “**MODEM BEREIT**”.

The used TeleService software is usually executed on the computer which is connected with the standard modem.

7.3.3 TS – Software Configuration

- a. SIMATIC Step7 v5.3 with TeleService v6.0
- b. MPI – Cablemanager v2.07

a. SIMATIC Step7 v5.3 with TeleService v6.0

a1. Start your Step7 software.



a2. Left-click on *Extras* → *PG/PC-Schnittstelle einstellen...*

a3. In the rising dialog select the *TS Adapter* using the *Benutzte Schnittstellenparametrierung* - listbox.

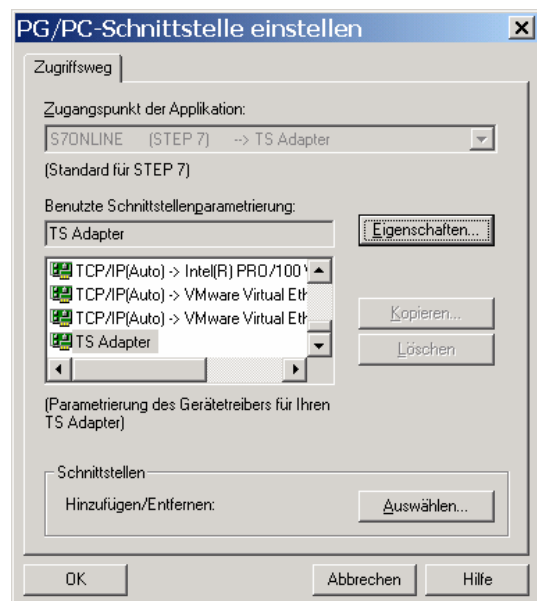

a4. Click on *Properties* and activate, in the registry card *Lokaler Anschluß*, the *Modemanschluß* Button. Confirm this configuration with *OK*.

a5. Close the dialog with *OK*.

Handbook Cable & Adapter

a6. Start the TeleService software via *Extras* → *TeleService* in the SIMATIC Step7 Manager.

a7. Start the configuration dialog by using the menu *Extras* → *Einstellungen*.

a8. Set up the *Rufnummer* of the MPI – Modem. This is done in the registry card *Allgemein*. Confirm your configuration with *OK*.

If you already have configured a telephone book you can go on with step a12 otherwise go ahead with step a9.

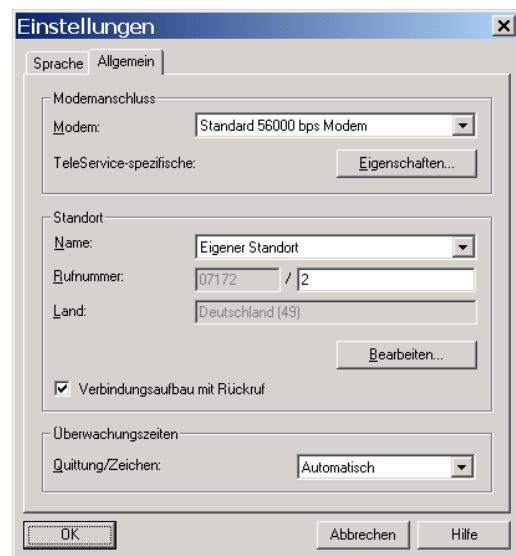
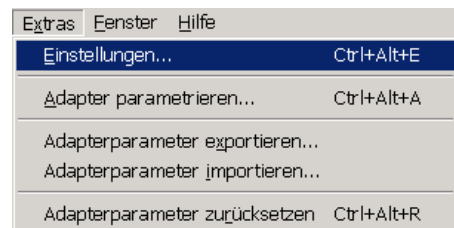
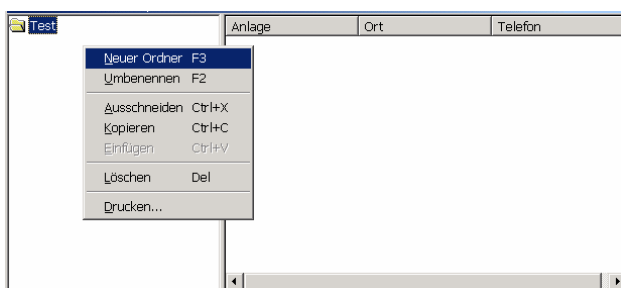

a9. With the menu *Telefonbuch* → *Neu* you can create a new project which is an empty window splitted into two parts. Right-click in the left part to open the context menu. From there choose *Neuer Ordner*. Name this folder as you wish.

a10. This time right-click again in the left part of the window and choose from the context menu *New Plant*.

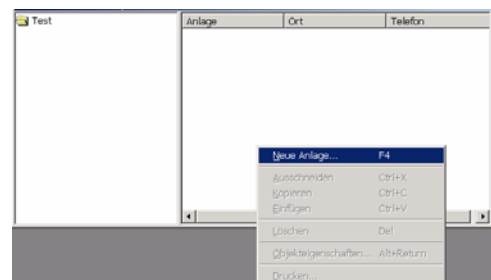

a11. Name the new device and configure as calling number the station address of the MPI – Modem in the second textbox from *Rufnummer*.

Confirm you configuration with *OK*.

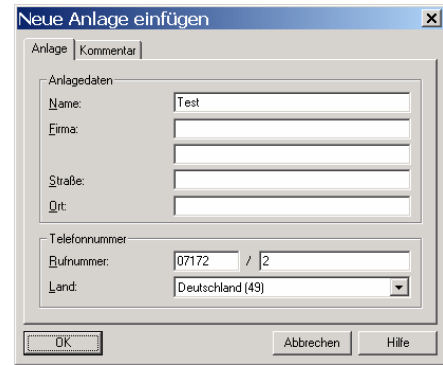

a12. Select the newly created device (or one of your devices you have created earlier) and click on *Verbindung* → *Aufbauen*.

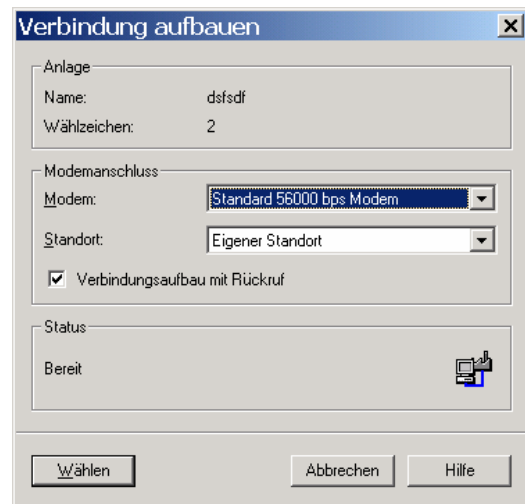

a13. A new dialog appears. Choose the *modem* you want to use/is connected with you computer and wether the connection should be established with a callback or not.

Connection establishment with call-back

The function “direct call-back“ is used to shift the phone costs to the called number.

In the next step you will be asked (only if activated) to enter the username, a password and the source phone number. The MPI – Modem gets the command to perform a call back to the given phone number. From now on the connection will be established by the modem. You can work on the PLC but the connection has been established by the modem far away from your position.

a14. Start the connection with *Wählen*. As soon as the connection is established you have to logon to the TS adapter. Standard – *User is ADMIN*



Handbook Cable & Adapter

without a *password*. Additionally you can setup the callback number.

Be sure that this callback number is not the same like the MPI – Modem which has been used to create this connection.

a15. As soon as the dialog disappears the connection is established. Now open the dialog to configure the adapter.
(Extras → Adapter parametrieren).

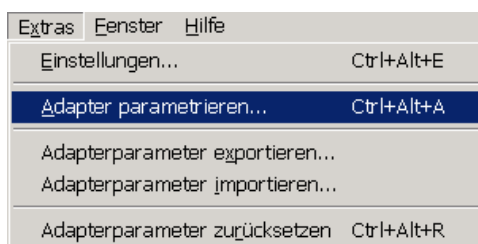

a16. Registry card *Netz*: Configure the net - parameters like the *Nettype*, the *transferrate*, the *highest station adresse* and the *profile*. This step is important for the software to communicate with the hardware.

a17. Registry card *Modem*: Use this dialog for the modem configuration. Set up parameters like the *initialization string* and the string for the *disconnect*.

a18. Registry card *Zugriffsschutz*: Create new users with their own *callback numbers*. Also you can set a new *password* (which is not set in standard) for the *administrator*.

Confirm with *OK*. The connection is now established successfully.

With *Verbindung* → *Trennen* you can close the connection.

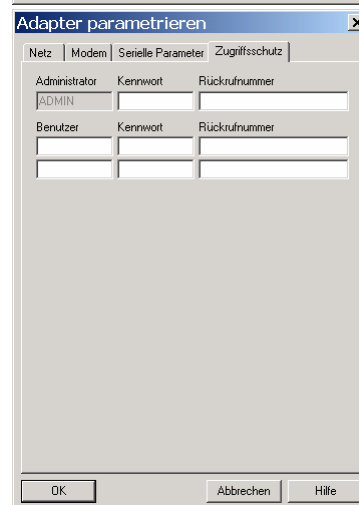
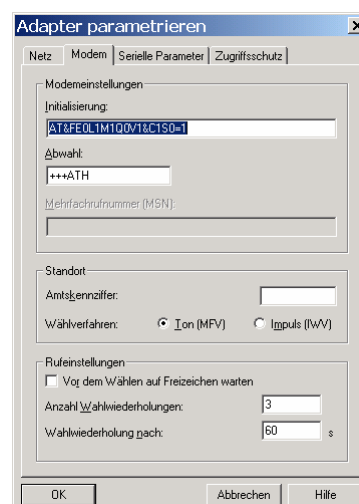
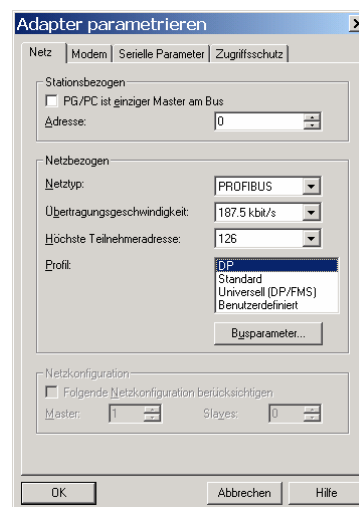

b. MPI – Cablemanager v2.07

b1. Start the MPI – Cablemanager by using the entry in your start menu.

b2. Choose from the registry card *Teleservice* the registry card *Extra* and click on *Check adapter*.

b3. A new dialog appears. Choose *MODEM* because this connection should be established via modem.

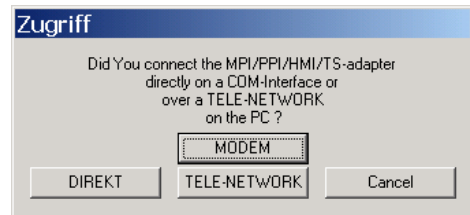

b4. In the *call-settings* set up the *Phone-Number* by using the station address of the MPI – Modem. Confirm with *OK*.

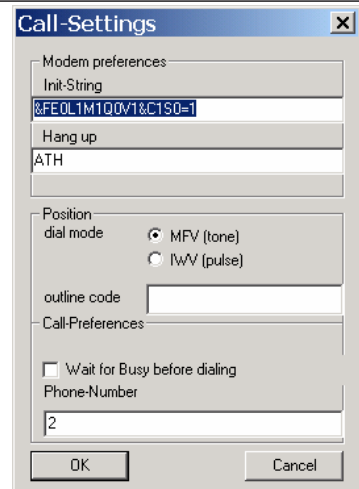

b5. After the connection is established new buttons will appear in the dialog. Click on *Adapter configuration*.

b6. The next dialog asks for the TeleService software version you want to use with the MPI – Modem. This description uses the version 6.0. Answer the question with *yes*.

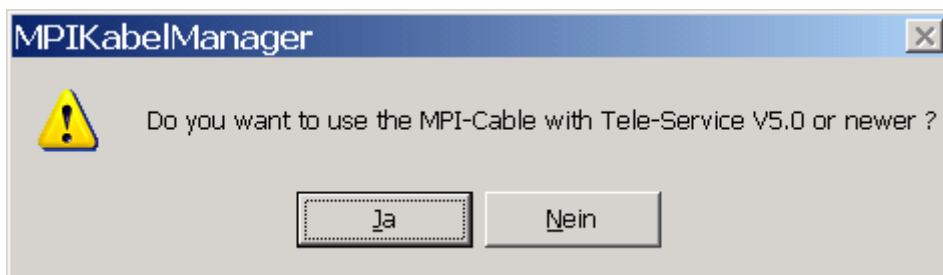
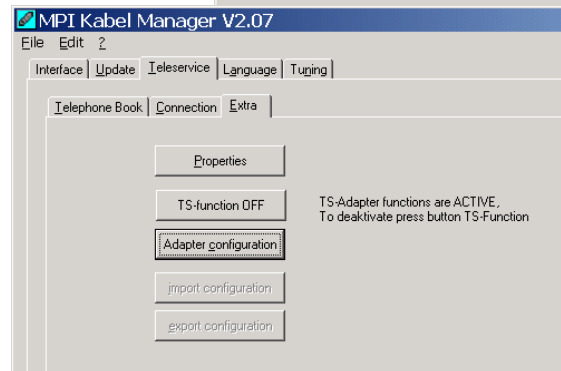

Handbook Cable & Adapter

b7. The adapter configuration dialog offers a lot of parameters to configure.

b8. The registry card *Net* finden Sie die *Netzbezogenen* Einstellungen. Diese Einstellung ist wichtig damit Software und Hardware auf dem gleichen Netz kommunizieren.

b9. The registry card *Modem* offers the *initialization string* and a lot more parameters like the *position-* and the *calling* – setup.

b10. In the registry card *Password* you can set up the *administrator password* (which is not set by default) and create new *users*. Every user, even the *administrator*, can have its own *back-calling number*.

The screenshot shows the 'Adapter configuration' dialog with the 'Net' tab selected. It contains the following fields:

- Stations:** A checkbox for 'PG/PC is the only Master' (unchecked) and an 'Adress:' field with the value '0'.
- Network:** A 'Type of net:' dropdown menu set to 'MPI', a 'Transfer-rate:' dropdown menu set to '187,5kBit', and a 'Highest station adress:' dropdown menu set to '126'.

The screenshot shows the 'Adapter configuration' dialog with the 'Modem' tab selected. It contains the following fields:

- Modem-Setup:** An 'Init:' field with the value 'AT&FE0L1M1Q0V1&C1S0=1' and a 'Hang-Up' field with the value '+++ATH'.
- Position:** A 'Dialing' section with radio buttons for 'MFV (Tone)' (selected) and 'fWV (Pulse)', and an 'Outline-Code' field.
- calling setup:** A checkbox for 'wait on free line before dialing' (unchecked), a 'Number of retries' field with the value '3', and a 'Retries after' field with the value '60' and the unit 'Sec'.

The screenshot shows the 'Adapter configuration' dialog with the 'Password' tab selected. It contains the following fields:

Administrator	Password	Back-calling number
ADMIN	<input type="text"/>	<input type="text"/>
User	<input type="text"/>	<input type="text"/>
	<input type="text"/>	<input type="text"/>

The connection is established successfully.

7.4 Pin assignment

7.4.1 Pinning RS232 (PC-side)

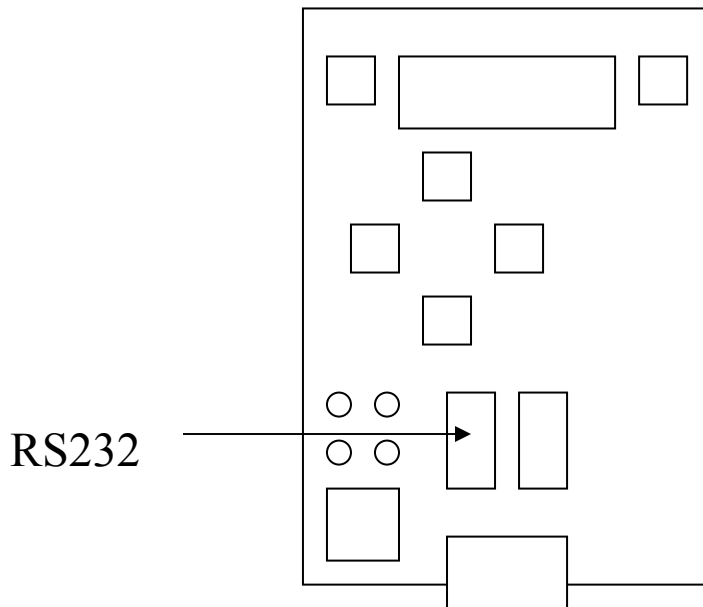

Pin No.	Notation	Description	Direction (of cable)
1	DCD	Data Carrier Detect	Out
2	TXD	Transmitted Data	Out
3	RXD	Received Data	In
4	DSR	Data Set Ready	In
5	GND	Signal Ground	
6	DTR	Data Terminal Ready	Out
7	CTS	Clear to Send	In
8	RTS	Request to Send	Out
9	RI	Ring Indicator	In
Shield		On connector casing	

The shield is connected with the RS232 connector via the shield of the adapter casing. This MPI-Modem is designed to be connected directly on a COM interface of a PC. The cable can be lengthened by a 1:1-cable to the PC up to 15m maximum. The cable should have a good quality and the shield should be connected at both sides at the SUB-D case.

7.4.2 Pinning MPI (PLC-side)

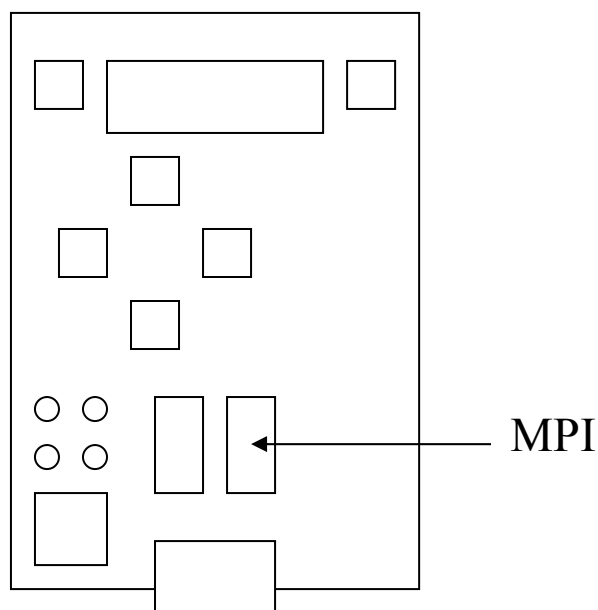

Pin No.	Notation	Description	Direction (of cable)
1	NC	Not Connected	
2	NC	Not Connected	
3	Ltg_B	Data line B	BiDir.
4	RTS-AS	Request to Send from the PLC	In
5	M5V	Ground of the 5V	In
6	P5V	5V output	Out
7	NC	Not Connected	
8	Ltg_A	Data line A	BiDir.
9	RTS-PG	Request to Send to the PLC	Out
Shield		On connector casing	

The shield is attached with the MPI connector via the shield of the adapter casing. To find directly attended PLC's , RTS-AS and M5V must be connected in the cable. P5V means a output of the cable and works only as an output for a bus-termination with resistors. This 5V output doesn't drive any load and have a 100R resistor inside his direction.

Attention:

Don't lengthen the connection by a 1:1 cable to the PLC, because there are 24V and 5V inside of the cable. The quality of the bus-signal will be risen down!

To lengthen the connection, please use a MPI-NETZ-Adapter and connect only the signals Ltg_A and Ltg_B 1:1 and the shield at both sides of the metal-casing at the SUB-D connector.

7.4.3 External power connector

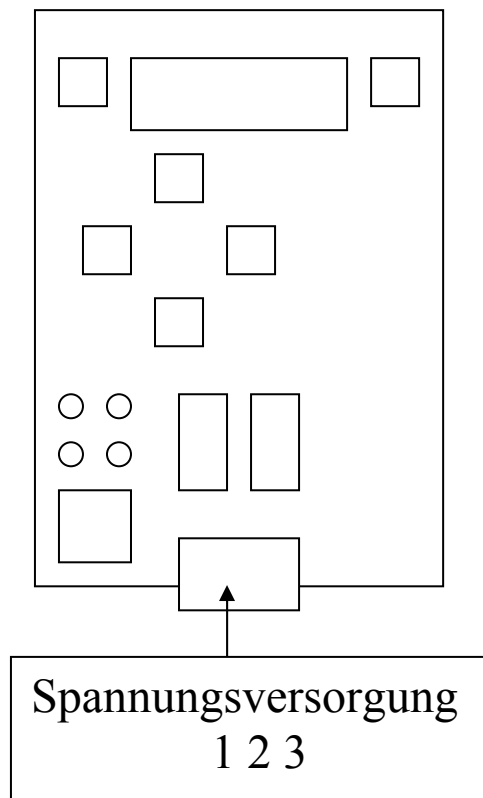

Pin No.	Notation	Description	In/Out (of Cable)
1	P24V	24V Power	In
2	GND	Ground	In
3	M24V	Ground 24V	In

You need a power-supply +24VDC +/- 20%, 5VA. The protective ground could also be connected to a cable-shoe on

Handbook Cable & Adapter

the bottom of the powder-coated metal-case. The Powder-coated case is isolating, mounting to the back-plane does **not** connect to protective ground !

7.4.4 Light emitting diode's

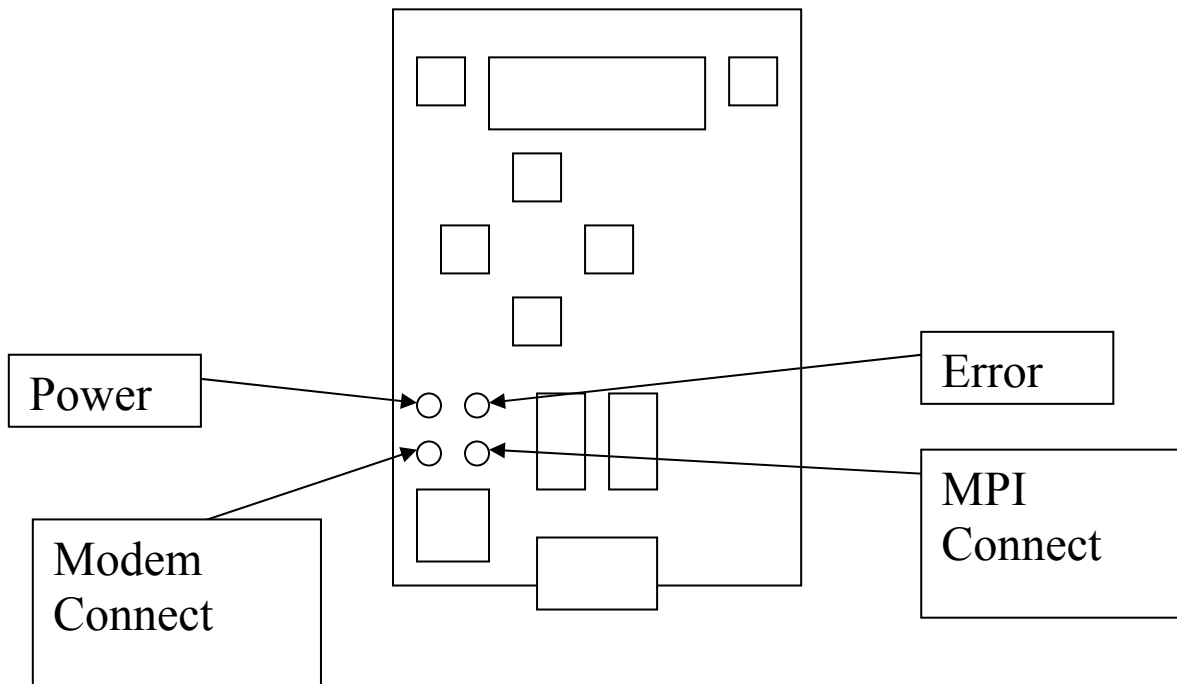

LED	Color	Position
Power	Green	upper left
Error	Red	upper right
Phone connection established	Yellow	lower left
MPI-Connection	Yellow	lower right

7.4.5 Analogue phone connector

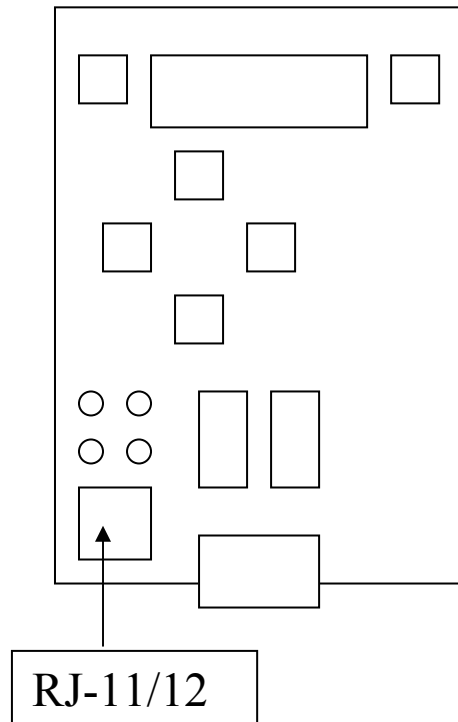

Pin No	Notation	Description	In/Out (of cable)
1	NC	Not connected	
2	A'	Pass-through line A	Out
3	A	Line A	In
4	B	Line B	In
5	B'	Pass-through line B	Out
6	NC	Not connected	

Analogue female Phone-Connector RJ-11/12, in China use the DDE-Net (recommended).

7.5 Connecting the MPI-Modem

This MPI-Modem will be connected with the right connector to the MPI- or the DP/FMS-Interface of the PLC. The MPI-Modem is power supplied with an external 24V voltage.

The left connector could be connected to the programming-device or with an PC to the COM-Port.

When the MPI-Modem gets the power it shows the software-version in the display and begins with the test of its internal components. On the display all relevant data is displayed.

The cable will find at a MPI-Connection the active baud rate to the programming-device or to the PC in the first time of communication and set his baud rate himself.

If you want to connect the cable to the 25-pin connector of the PC, you can use an adapter (9 pin to 25 pin sub miniature D-connector) to work with this port.

In the PC-Software you must adjust some parameters like the baud rate (19,2 or 38,4 kbaud) and the connected COM-PORT (COM1 or COM2) and the used adapter as 'TS-Adapter'.

7.6 Display and keyboard of the MPI-Modem

After Reset the Display shows all relevant Data of the PLC-Connection.

Example for Display:

```
#02TD00 | MODEM BE  
!02AG04 |
```

In the first line there are displayed from left to right the following Information:

1.) A Sharp „#“ with the number of connected active stations on the MPI-Bus (in this example 2)

2.) The PC-Baud rate

MD	115,2k or automatic Baudrate-Selection active (Modem)
TD	115,2k or automatic Baudrate-Selection active (serial line)
MS	19,2k (Modem)
TS	19,2k (serial line)
Ms	38,4k (Modem)
Ts	38,4k (serial line)
mS	57,6k (Modem)
tS	57,6k (serial line)

3.) The station-number of MPI – II Cable (In S7-Manager under „Extras / PG/PC-Interface“ with “Properties/Net/locale station number“). The default is 0.

4.) When communicating a tiled bar (top is to PLC, bottom to PG)

In the second line there are display from left to right the following information:

1.) The first Char defines which type of PLC and which connection is used

!	Active Station in MPI-Bus, directly connected
---	---

Handbook Cable & Adapter

?	Active Station in MPI-Bus, far distance
!	Passive Station in MPI-Bus, directly connected
?	Passive Station in MPI-Bus, far distance

2.) The station-numbers of all active and connected stations in the MPI-Bus. Every $\frac{3}{4}$ second another station is displayed.

3.) static Text „AG“ (means PLC)

4.) The PLC which is momentarily is connected to the PC-Software (in our example is the Station 4 connected).

On the right side of the display, separated by “|”, is the modem-state displayed.

In the first line the following messages could appear:

Message	Description
MODEM READY	The modem is booted and ready
MODEM ERROR	The modem reports an error
NO ANSWER	The modem don't send an answer
RING	The modem is called
CON.END	The connection is terminated
CONNECT <Bd>	The modem is connected to a line with the displayed Baudrate
NO CARRIER	The carrier is lost.
LINE BUSY	The phone-line or number is busy
BLACKLISTED	The called number is not allowed in the modem

NR.DELAYED	The number called is too often or fast redialed. The dialing is not allowed for a minute
FAX	Fax-call detected
DATA	Data-call detected
UNKNOWN MESS.	The modem generates an unknown message
DIALING	The phone-number which is dialed is shown in the bottom line
ENTRY EMPTY	The Fast-Access Entry is Empty
wrong PIN	The PIN-number configured is wrong
SIMCard wrong	The SIM-Card is not inserted, or not correctly placed.

In the GSM-Version the display shows in the bottom line additional information about the GSM-Network:

Display	Description
SIM/PIN	SIM Card not inserted or PIN-Number wrong
RegDend	Registration denied in the GSM-network
Unknown	Unknown state
ROAM:<xx>	Connection established to a provider which is roaming. This could produce higher costs
GSM:<xx>	Connection established to a provider.
Srch:<xx>	Searching provider in GSM-network, not yet found

At „ROAM“, „GSM“ and „Srch“ additionally the Recieve-Quality is displayed (greater values are better).

- no recieve (antenna not connected?)
- 01 very bad
- 31 best and optimal

7.6.1 The keyboard

The keyboard on the MPI-Modem is used for navigating through menus and for configuring the MPI-Modem. There are the following keys sensing and colored:

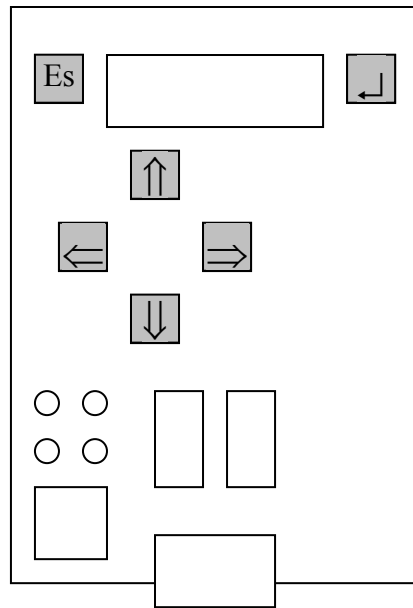

	Confirm the input. Saves the configuration permanently into the flash-memory. Change into a menu or menu-point	ENTER
	Increasing a value, selecting a menu-point	UP
	Decreasing a value, selecting a menu-point	DOWN
	Cancellation of a input/selection, the selection is not saved, one menu-level back	LEFT
	Go into a sub-menu	RIGHT
	Go to state-message area	ESC

7.6.2 Main menu

You select the main-menu with ENTER, with ENTER again you reactivate the default-display. On the Main-menu you could also select the default-display with LEFT.

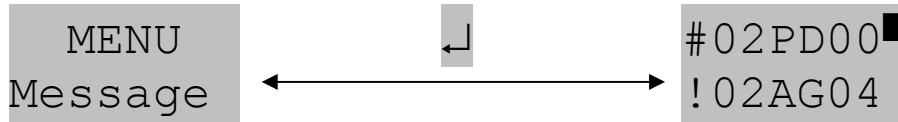

With UP/DOWN you could choose the following menu-points:

Message	activate default-display
Info	Information over the MPI-MODEM cable
Bus	MPI-Bus information's
Config	Configuration of the cable
Hang up	tells the modem to hang up
Call	establishes a connection

7.6.3 Info

With RIGHT or ENTER you select the following sub-menu:

```
Info
Version
```

```
Info
Signal quality
```

```
Info
Signal level
```

Handbook Cable & Adapter

7.6.3.1 *Version*

With RIGHT or ENTER you will enter the following display, which will display the actual operation system version of the cable:

```
Version  
1.01
```

With LEFT or ENTER you will leave this sub-menu-point to the menu info.

7.6.3.2 *Signalquality*

With RIGHT or ENTER you will enter the following display, which will display the actual signal quality of the connection:

```
Signalquality  
255
```

With LEFT or ENTER you will leave this sub-menu-point to the menu info.

7.6.3.3 *Signallevel*

With RIGHT or ENTER you will enter the following display, which will display the actual signal quality of the connection:

```
Signallevel  
21
```

With LEFT or ENTER you will leave this sub-menu-point to the menu info.

7.6.4 Bus

With RIGHT or ENTER you enter the following sub-menu which has only one element:

```
Bus
Address
```

With LEFT you leave this sub-menu to the main-menu. With ENTER you enter the sub-menu.

7.6.4.1 Adresses

With RIGHT or ENTER you enter the following display, which shows the connected stations on the MPI-Bus:

```
Adressen
D 018
```

With UP or DOWN you browse the addresses, where in the second line the following chars are possible:

D	The MPI-MODEM Cable is connected directly to this station
A	This station is active in the BUS
P	This station is passive like for example some OP's, FM or Profibus-Slaves.

With LEFT or ENTER you leave this sub-menu to the menu info.

7.6.5 Config

With RIGHT or ENTER a Password request is displayed. The Standard Password is "0". With ENTER you enter the following sub-menu where you could select the following sub-menus:

```
Config
PG/PC
```

With UP/DOWN you could choose the following sub-menus:

PG/PC	For selecting the function of the Cable.
Data	Selection if locked (at MPI-Modem default)
Modem	configure the Modem
MPI-BUS	Configuration of the MPI-Parameter
Protocol	Communication protocol to PC
Language	Selection of the Menu-Language
Set.Def	erases the Configuration, the Default- Properties are loaded
Reset	Resets the modem
Password	Define a new Password

With LEFT you leave this sub-menu to the main-menu. With ENTER you enter the sub-menu.

7.6.5.1 PG/PC

With RIGHT or ENTER you enter the following sub-menu where you could select following menu-points:

```
PG/PC
MPI Accs
```

With UP/DOWN you select the following menu-points:

MPI Accs	The cable acts in a MPI-Bus
PPI Accs	The cable is connected to a S7-200

With LEFT you will leave this sub-menu to the menu mode.

7.6.5.1.1 MPI Accs

With RIGHT or ENTER you enter the following sub-menu where you could select following menu-points::

```
MPI Accs
Serial
```

With UP/DOWN you select the following menu-points:

Serial	Connect the PC over the serial line RS232
MODEM	Connect the PC over Telephone-line with the internal MODEM.

With LEFT you leave this sub-menu to the main-menu. With ENTER you enter the sub-menu.

7.6.5.1.1.1 *Serial*

With RIGHT or ENTER you enter the following sub-menu where you could select following menu-points::

```
Ser.Baud
19.2k
```

With UP/DOWN you select the following menu-points, with ENTER the selection is used:

19.2k	Baudrate 19200
38.4k	Baudrate 38400

Handbook Cable & Adapter

57.6k Baudrate 57600

115.2k Baudrate 115200

Auto The MPI-Modem selects automatically the baudrate

With LEFT (Cancel) or ENTER (Select) you will leave this Menu and go to PG/PC.

7.6.5.1.1.2 Modem

With ENTER the Modem is the Accespoint.

7.6.5.1.2 PPI-Accs

With RIGHT or ENTER you enter the following sub-menu where you could select following menu-points::

```
MPI-Accs
Serial
```

With UP/DOWN you select the following menu-points:

Serial	Connect the PC over the serial line RS232
MODEM	Connect the PC over Telephone-line with the internal MODEM.

With LEFT you leave this sub-menu to the main-menu. With ENTER you enter the sub-menu.

With RIGHT or ENTER you enter the following sub-menu where you could select following menu-points:

7.6.5.1.2.1

Serial

```
Ser.Baud  
 9.6k
```

With UP/DOWN you select the following menu-points, with ENTER the selection is used:

```
9.6k    Baudrate 9600  
19.2k   Baudrate 19200
```

With LEFT you leave this sub-menu to the main-menu.

7.6.5.1.2.2

Modem

With RIGHT or ENTER you enter the following sub-menu where you could select following menu-points::

```
ModmBaud  
 9.6k
```

With UP/DOWN you select the following menu-points, with ENTER the selection is used:

```
9.6k    Baudrate 9600  
19.2k   Baudrate 19200
```

With LEFT you leave this sub-menu to the main-menu.

7.6.5.1.3 TrnModem (transparent modem mode)

This option makes the device use a external modem, instead of the built-in, internal modem of the device. The external modem must be connected with the RS232 interface of the mpi-modem. Select this option by pressing ENTER or

Handbook Cable & Adapter

RIGHT, then you'll be asked of the baudrate with which the external modem will be driven:

```
Ser.Baud  
  19.2k
```

Choose the desired baudrate and confirm your changes with ENTER, or discard them with LEFT.

After this, you will be asked of the AT-Initstring of your external modem. With the keys LEFT/RIGHT you can move the cursor, this UP/DOWN you can edit the characters of the AT-initstring. To obtain more information about the appropriate initstring, refer to the documentation included with your external modem.

The modem now restarts and will use the modem which is externally connected to the RS232 interface of the mpi-modem.

7.6.5.1.4 ExtModem (external modem mode)

With this option you can use the mpi-modem as a ordinary, external modem. To use it this way, just connect the mpi modem via the RS232 interface and use it like a external modem.

Choose this mode by pressing ENTER, you will be asked of the baudrate with which the RS232 interface will be driven. Select your desired speed and confirm your changes with ENTER.

After the modem has rebooted, the external modem-mode is active.

To return to the normal mode, select Config->PG/PC->MPI Accs in the menu.

7.6.5.2 *Data*

With RIGHT or ENTER you enter the following sub-menu where you could select following menu-points::

```
PCConfig
locked
```

With UP/DOWN you select the following menu-points:

locked The MPI-Bus is fully configurated in the MPI-Modem or by TeleService-Software.

unlocked MPI-Bus Parameters are transfered defined by PC-Software (not expected for MPI-Modem)

With LEFT/ESC you leave this Sub-Menu to Config discarding your changes, ENTER saves your changes.

7.6.5.3 *Modem*

With RIGHT or ENTER you enter the following sub-menu where you could select following menu-points::

```
Modem
dial mode
```

With UP/DOWN you select the following menu-points:

Dial mode	dial by tone or pulse
Phonebook	edit entries in the phonebook
Baudrate	Modem-baudrate over telephone line

Handbook Cable & Adapter

Modemtype	select modemtype
Speaker	Speaker loudness
Busy identify	select busy identify
Ring counter	automatic connection
Extension	use extension
Outline code	if extension then define the outline code

With LEFT you leave this sub-menu to the main-menu. With ENTER you enter the sub-menu.

7.6.5.3.1 Dial mode

With RIGHT or ENTER you enter the following sub-menu where you could select following menu-points::

```
Dial mode
Tone
```

With UP/DOWN you select the following menu-points, with ENTER your selection is used:

tone	dialing with tones
pulse	dialing with pulses

7.6.5.3.2 phone book

With RIGHT or ENTER you enter the following sub-menu where you can choose the phonebook entry to edit.

```
phonebook entry:
  1
```

Use UP und DOWN to select the phonebook entry. By pressing ENTER you can edit the entry.

```
phonebook entry:  
> <
```

With UP/DOWN/RIGHT/LEFT you can edit the phonebook entry. ENTER saves your changes, ESC will cancel the action.

7.6.5.3.3 baudrate

With RIGHT or ENTER you enter the following sub-menu where you could select following menu-points::

```
Baudrate  
300 Bd
```

With UP/DOWN you select the following menu-points, with ENTER your selection is used:

300	1200	2400	4800	7200	9600
12000	14400	16800	19200	21600	24000
26400	28000	31200	33600		

automatic The Modem selects the appropriate baudrate by self.

7.6.5.3.4 Modemtype

With RIGHT or ENTER you enter the following sub-menu where you could select following menu-points::

```
Modemtyp  
D
```

Handbook Cable & Adapter

With UP/DOWN you select the following menu-points, with ENTER your selection is used:

D	Germany
USA	USA
Auto	Automatic Selection with telephone type is used.

7.6.5.3.5 Speaker

With RIGHT or ENTER you enter the following sub-menu where you could select following menu-points::

```
Lautsprecher  
Aus
```

With UP/DOWN you select the following menu-points, with ENTER your selection is used:

Off	Speaker is off
Silent	Speaker is silent
Middle	Speaker is on normal Loudness
Loud	Speaker is at maximum Loudness

7.6.5.3.6 Busy identification

With RIGHT or ENTER you enter the following sub-menu where you could select following menu-points::

```
Busy identify  
YES
```

With UP/DOWN you select the following menu-points, with ENTER your selection is used:

YES busy identify is used
NO busy identify is NOT used

7.6.5.3.7 Ring counter

With RIGHT or ENTER you enter the following sub-menu where you could select following menu-points::

```
Ring counter  
1
```

With UP/DOWN you select the ring counter, the value can be between 0 (no answer on call) to 9.

7.6.5.3.8 Extension

With RIGHT or ENTER you enter the following sub-menu where you could select following menu-points:

```
Extension  
YES
```

With UP/DOWN you select the following menu-points, with ENTER your selection is used:

YES extension is used
NO extension is NOT used

7.6.5.3.9 Outline code

With RIGHT or ENTER you enter the following sub-menu where you could select following menu-points:

```
Outline code
```

Handbook Cable & Adapter

With UP/DOWN/RIGHT/LEFT you can select the extension which is preceded before all outgoing calls. With ENTER the selection is used.

7.6.5.4 *MPI-Bus*

With RIGHT or ENTER you enter the following sub-menu, in which you could choose following sub-menus:

```
MPI-BUS
Baudrate
```

With UP/DOWN you could enter the following sub-menus:

Baudrate	MPI-Baud rate configuration, the baud rate selected here is used, even when another is selected over the PG/PC on connection to PLC.
HSA	select highest station address
local Nr	select local stations address for the cable
Master	select if MPI-Modem is the only active Station on MPI-BUS
Profil	select the MPI/DP-Bus-profile

with LEFT you leave this sub-menu to the menu config. With ENTER you enter the sub-menu.

7.6.5.4.1 Baudrate

With RIGHT or ENTER you enter the following sub-menu:

```
MPI-Baud
187.5k
```

With UP/DOWN you could choose between the following baud rates. With ENTER the baud rate is selected:

12M	6M	3M
1.5M	500k	187.5k
93.75k	45.45k	19.2k

from PC the baudrate which is transferred from PC
 is used

With LEFT (Cancel) or ENTER (Select) you leave the sub-menu to the menu MPI.

7.6.5.4.2 HSA

With RIGHT or ENTER you enter the sub-menu:

```
HSA  
31
```

With UP/DOWN you could choose between the following values, with ENTER you select the value:

126	63	31	15
-----	----	----	----

With LEFT or ENTER you leave this sub-menu to the menu MPI.

7.6.5.4.3 Local nr.

With RIGHT or ENTER you enter the following Sub-Menu:

```
lokaleNr  
0A
```

With UP/DOWN the local station number is increased/decreased with one. With RIGTH/LEFT the station

Handbook Cable & Adapter

number is increased/decreased by 16. The local station number is displayed in hexadecimal.

With ENTER you leave this sub-menu to the menu MPI.

7.6.5.4.4 Master

With RIGHT or ENTER you enter the following Sub-Menu:

```
Multi  
master
```

With UP/DOWN you select the following menu-points, with ENTER your selection is used:

Multimaster The MPI-Modem is in a MPI-Bus-System which has at least one additional active station (this is the default)

PGPC is singMast The MPI-Modem is connected to a single OP for Updateing purposes another PLC is not connected. In this very special case the MPI-Modem must drive the MPI-Bus stand-alone.

With LEFT/ESC (discarding changes) or ENTER (saving changes) you leave this sub-menu to the menu MPI.

7.6.5.4.5 Profil

With RIGHT or ENTER you enter the following Sub-Menu:

```
Profil  
MPI
```

With UP/DOWN you select the following menu-points, with ENTER your selection is used:

MPI The MPI-Modem is connected to a MPI-Bus,
 This is the default case (left Interface)

DP The MPI-Modem is connected to a Profibus with
 the profile-type DP (Decentral Peripheral)

DP/FMS The MPI-Modem is connected to a Profibus with
 the profile-type DP/FMS

Standard The MPI-Modem is connected to a Profibus with
 the profile-type Standard

Wich Profile-type is used could be reviewed in the hardware-configuration of your PLC.

With LEFT/ESC (discarding changes) or ENTER (saving changes) you leave this sub-menu to the menu MPI.

7.6.5.5 Protocol

With RIGHT or ENTER you enter the following Sub-Menu:

```
Protocol
Auto
```

With UP/DOWN you select the following menu-points, with ENTER your selection is used:

Auto The MPI-Modem detects itself the protocol
 type which should be used from PC.

Handbook Cable & Adapter

V5.1 The MPI-Modem tries to using the (faster) Protocol-types for communication to PC.

V5.0 Alt The MPI-Modem communicates only with the (older) protocol_types up to PC-Adapter V5.0

With LEFT/ESC (discarding changes) or ENTER (saving changes) you leave this sub-menu to the menu Config.

7.6.5.6 Language

With RIGHT or ENTER you enter the following sub-menu:

```
Language
German
```

With UP/DOWN you could select the following languages:

German	Language of menu is German
English	Language of menu is English

With LEFT you leave this Sub-Menu to the Menu config.
With ENTER you choose the language and the sub-menu is leaved to config.

7.6.5.7 Erase

The default-configuration is saved to OnBoard-Flash with the correct password.

7.6.5.8 Reset

With RIGHT or ENTER you enter the following sub-menu:

```
Reset
> <
```

To do a reset of the MPI-Modem the password must be given. With UP/DOWN you select the Chars and with RIGHT/LEFT the Position is changed.

The Reset occurs only with ENTER and of course a correct Password, Cancel with repeated LEFT in this case you go back to the upper menu Config.

7.6.5.9 Password

By pressing ENTER or RIGHT you can change your password:

```
Old    PW
> <
```

Input your old password. **The standard-password is „0“**

```
New    PW
> <
```

Input the new password.

```
Again
> <
```

Input the new password again.

```
PW übern
PW: 0 _____
```

7.6.5.10 Telemessage (optional)

This menu configures the (optional available) Telemessaging functions. With the Telemessaging function it is possible to send a fax, a sms, or a voice message after a signal on the mpi-bus.

7.6.5.10.1 SMS

By pressing ENTER or RIGHT you can configure the settings of the sms mode:

7.6.5.10.1.1 *Text*

Here you can edit the text which will be sent as a sms.

By pressing LEFT/RIGHT you can move the cursor, by pressing UP/DOWN you can edit the selected character of the message.

Confirm your changes by pressing ENTER, discard them with ESC.

7.6.5.10.1.2 *Tel.nr.*

With this option, you can edit the telephone number of the recipient of the short message. By pressing LEFT/RIGHT you can move the cursor, by pressing UP/DOWN you can edit the selected character of the message.

Confirm your changes by pressing ENTER, discard them with ESC.

You'll also be asked to select a protocol and a sms service number to finish the configuration.

SMS providers often use different protocols and server numbers.

Choose the sms server number and the protocol accordingly the following table:

Provider	Protocol	Nr. of Service Center
D1	TAP	01712521002
D2	UCP	01722278025
E-Plus	TAP	01771167

7.6.5.10.1.3 *Test*

By pressing ENTER or RIGHT you can test your settings by sending a test message.

7.6.5.10.2 Fax

7.6.5.10.2.1 *Text*

Here you can edit the text, which will be sent as a fax.

By pressing LEFT/RIGHT you can move the cursor, by pressing UP/DOWN you can edit the selected character of the message.

Confirm your changes by pressing ENTER, discard them with ESC.

7.6.5.10.2.2 *Tel.nr*

With this option, you can edit the telephone number of the recipient of the fax message. By pressing LEFT/RIGHT you can move the cursor, by pressing UP/DOWN you can edit the selected character of the message.

Handbook Cable & Adapter

Confirm your changes by pressing ENTER, discard them with ESC.

7.6.5.10.2.3 *test*

By pressing ENTER or RIGHT you can test your settings by sending a fax message.

7.6.5.10.3 Voice

7.6.5.10.3.1 *Tel.nr*

With this option, you can edit the telephone number of the recipient of the voice message. By pressing LEFT/RIGHT you can move the cursor, by pressing UP/DOWN you can edit the selected character of the message.

Confirm your changes by pressing ENTER, discard them with ESC.

7.6.5.10.3.2 *Test*

By pressing ENTER or RIGHT you can test your settings by sending a voice message.

7.6.6 Hang up

With RIGHT or ENTER you tell the modem to close an active connection and to hang up.

7.6.7 Call

With RIGHT or ENTER you select the following sub-menu:

```
phonebook entry:  
  1
```

UP and DOWN selects the phonebook entry, with ENTER the modem dials the number stored in the entry.

7.7 Technical data

Description	Technical specifications
Dimensions without cables	165 x 90 x 50mm (L x W x H)
Case type	Powder-coated, metallic case (Isolating, connect protective ground to connector on the bottom of the Device with a 6.3mm cable-shoe or power-connector)
Interfaces	
To the MPI-BUS	RS485(19,2/93,5/187,5/ 500kBaud, 1.5/3/6/12Mbaud)
To the PG/PC	RS232 19,2 / 38,4 / 57,6 / 115,2kBaud MODEM upto 33.6k
To Telephone-line	RJ-11/12
Supply voltage	DC 24V +/- 20% The 24V will be taken out of the connected PLC or of the connected adapter.
Power disurpation	5VA (Typ. I = 200mA at 24V)
Galvanic decoupling	The internal electronic (and RS232) to the bus driver and also to the 24V input are decoupled. The shield from the MPI/PPI side to the RS232 side are connected through

Order Description

MPI-Modem 3m

Order.No. 9352

8 The S7-Interface-Configurator (S7IFC)

The S7-Interface-Configurator (S7IFC) could used to update the following devices, in contrary to the MPI-Cablemanager no PLC-VCOM is needed:

- MPI/PPI Cable
- MPI-II Cable
- MPI-USB Cable
- MPI-Modem
- TELESERVICE
- MPI-LAN
- S7-LAN

8.1 Menubar

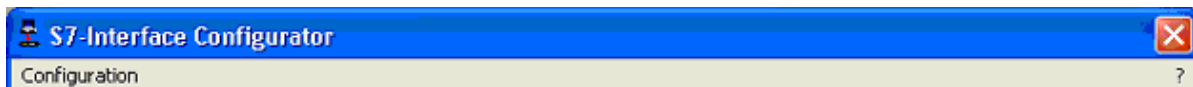

Select the menu „Configuration“ to change the language permanently:



Select the menu „?“ to get a short help.

8.2 Properties



Select on „Search“ which Interfaces are searched permanently for devices. You could choose:

Serial All existing COM-Ports are scanned for devices
USB search Devices which are connected by USB
LAN search devices on all network-cards

8.3 Buttons

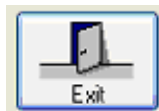

The button „Exit“ closes the Application



The button „Search“ starts a parallell search on all selected Interfaces



Selecting a device which could be updatet, the button „Update“ is available:

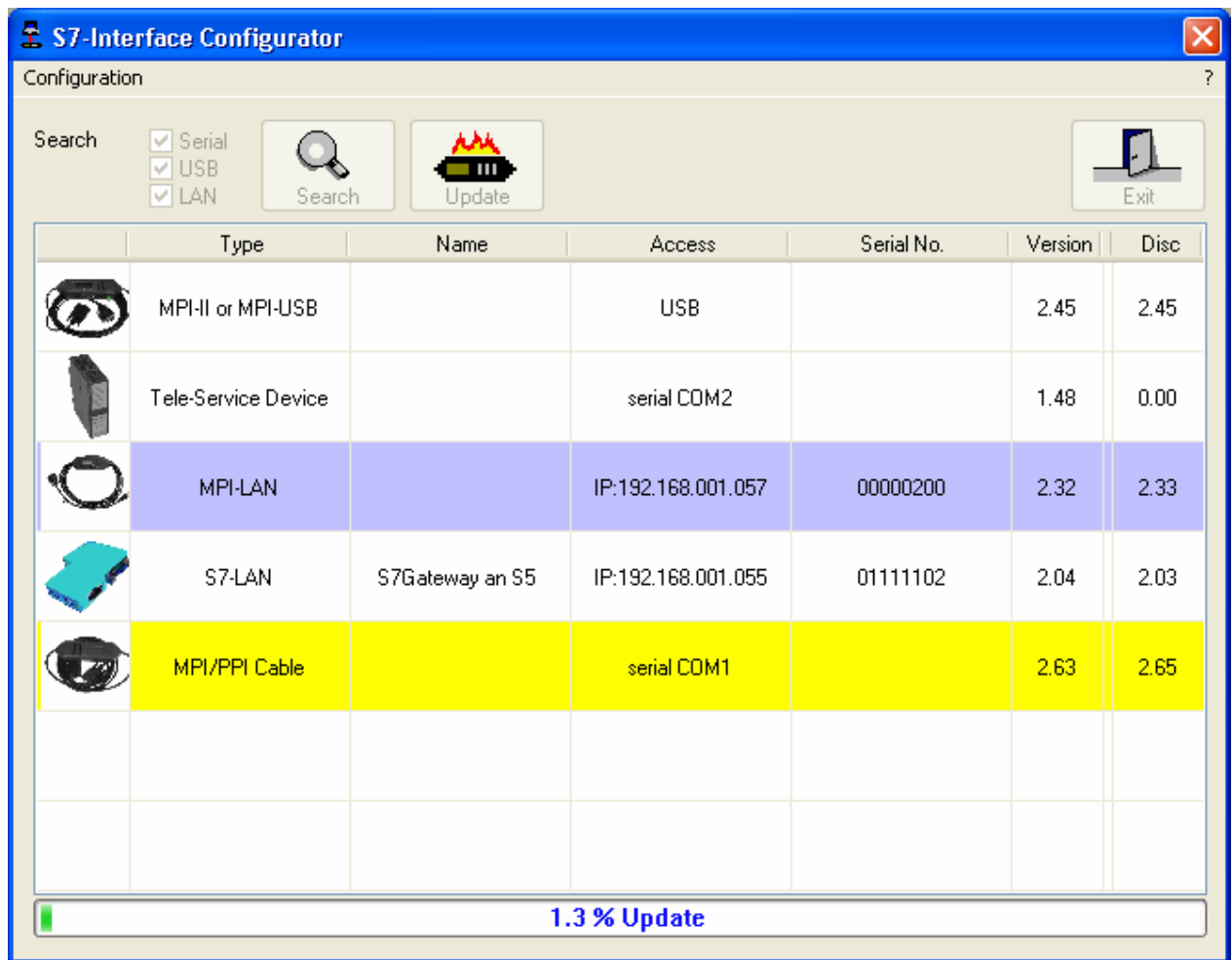

8.4 Display

Below the buttons, is a list of the found devices. In each line an image, the type of the device, name (if existing), interface, serial number (if possible) and the OS-version on the device is displayed. On the rightmost position the actual OS-version on the harddisc is displayed.

The background of the lines could use the following colours:

white	The OS of the device is actual
light blue	The OS of the device is older, the device could be updated
red	error accessing the device
yellow	Update is in progress for this device
dark blue	selected device

Handbook Cable & Adapter

Double click onto a device which could be updated shows the version-documentation of the device (only german!)

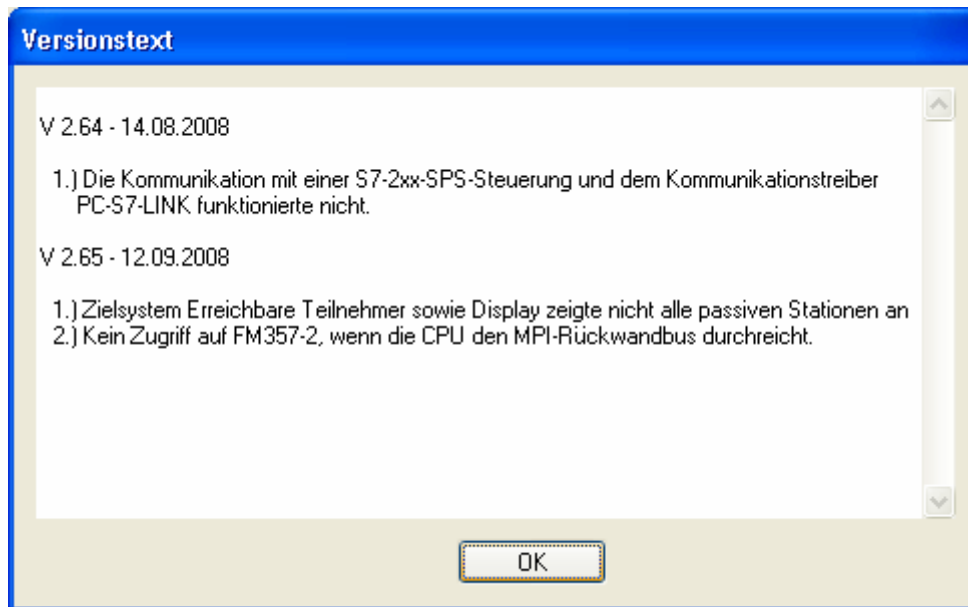

9 The MPI-Cablemanager

The MPI-cablemanager can be used to update the cable or to make settings of the cable, like the parameters of the TS function.

9.1 Language

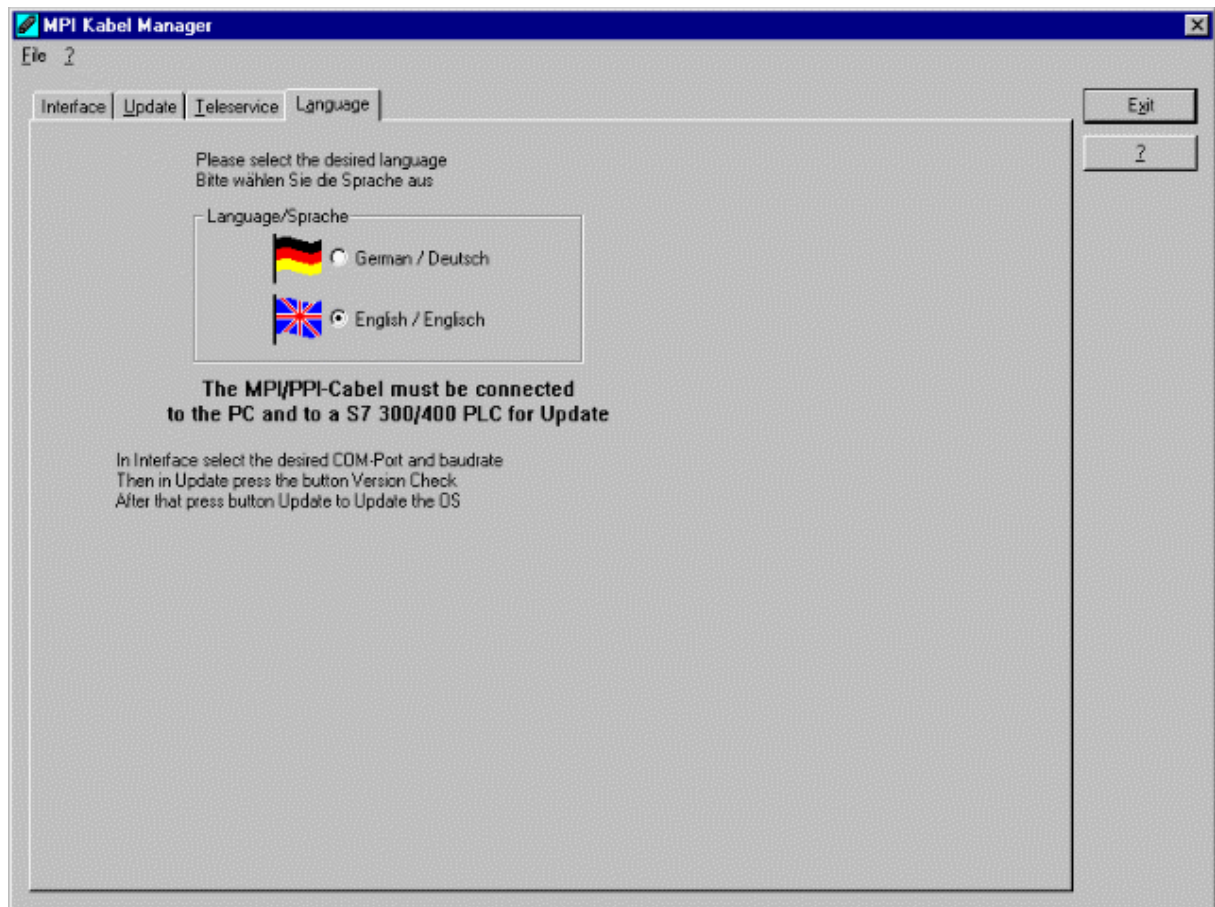

In this Dialog you could choose the used language in the application. You could choose between:

- German
- English

Click the radio-button to select the desired language. When the language is changing the application is “flicker” by construction.

9.2 Interface

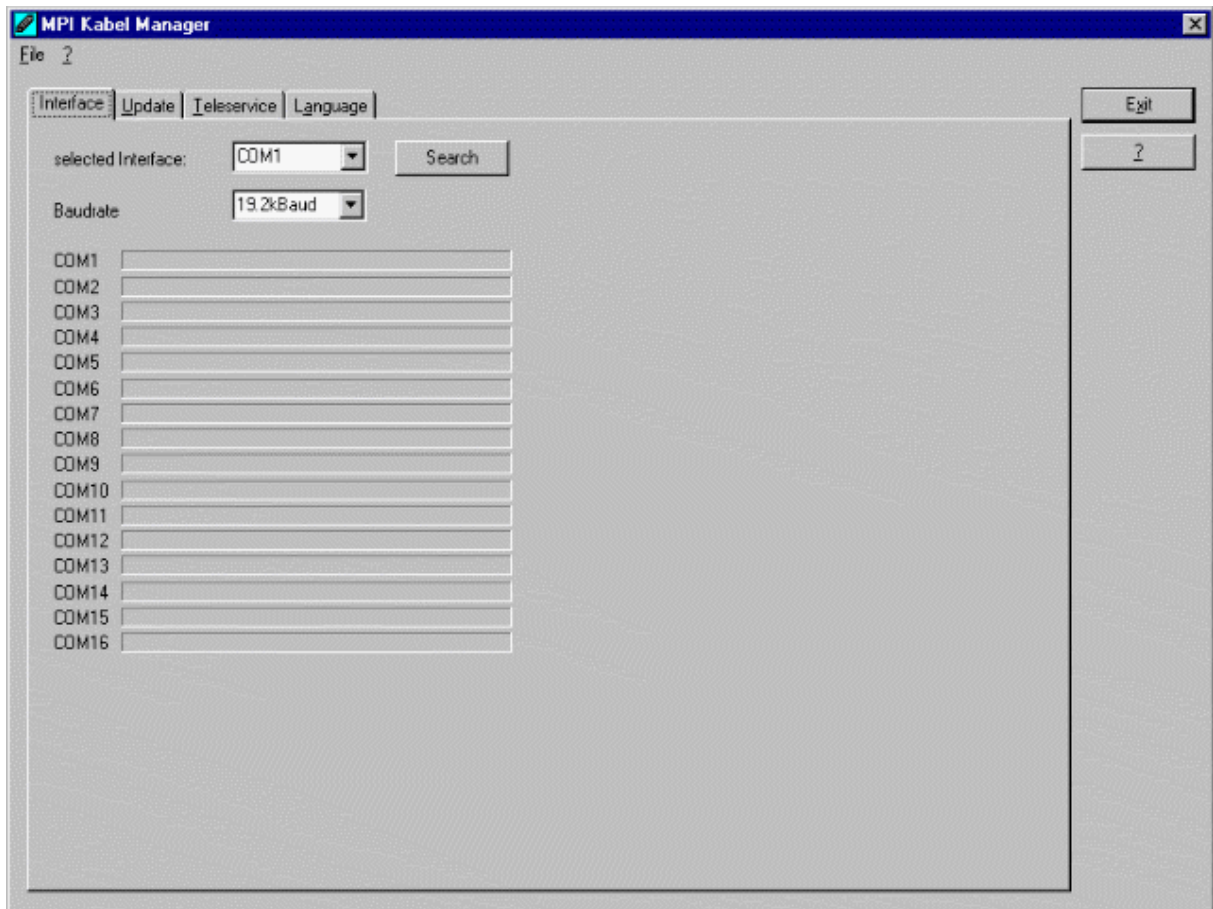

In this dialog you could define the COM-port and transfer-rate which is used for communication with the MPI-cable.

If you click on search, all 16 possible COM-ports are tested if there is a MPI-cable. If there is a MPI-cable detected then the corresponding COM-port and baud-rate is selected.

The settings of the COM-port can also be set manually.

9.3 Update

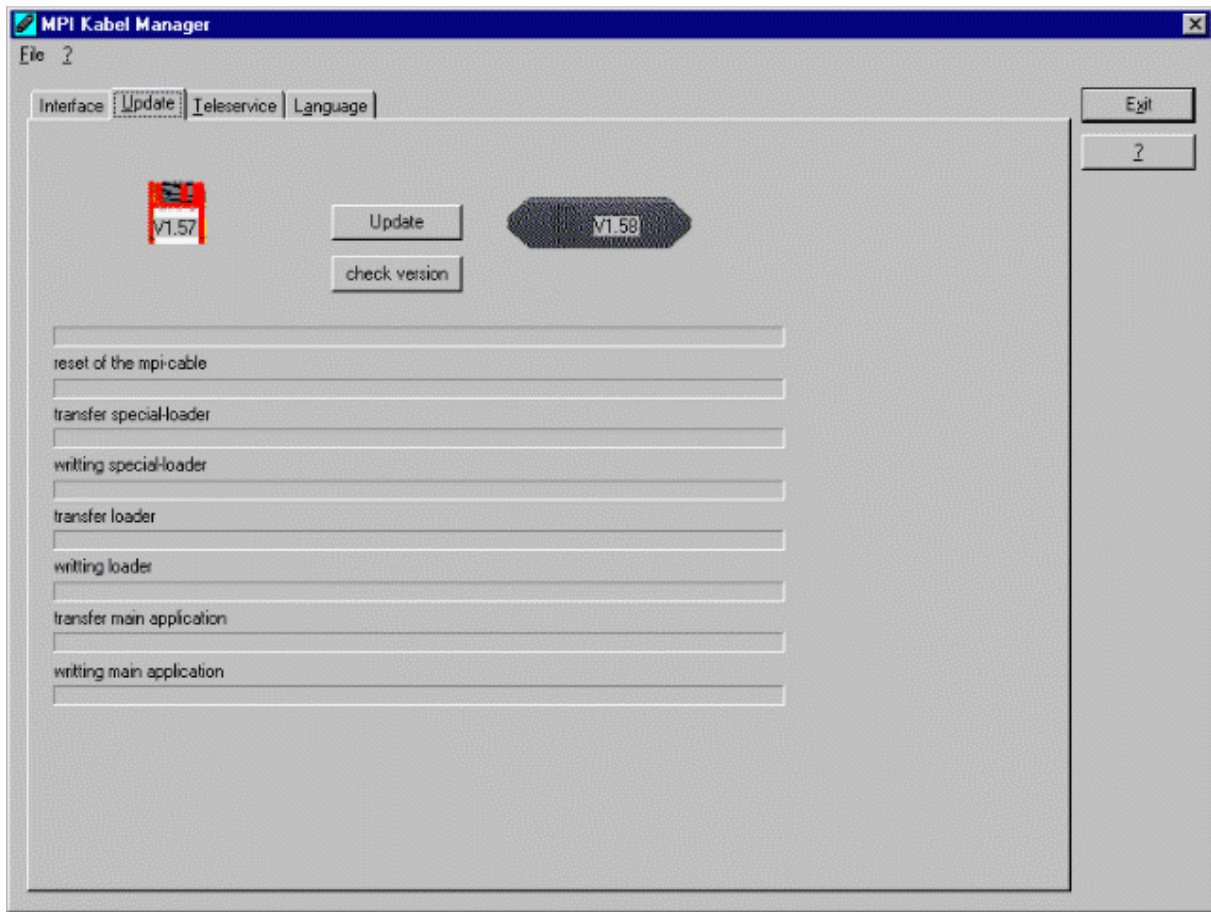

In this dialog you could display the actual version-information about the MPI-cable and the version which is situated on disk. Click on “check version” to read the desired version-info from disk and cable. This button must be pressed before you could update the MPI-cable. The version info is displayed at the disk and the cable on the screen..

Double-Click on the disk to select the operating system which is updated by yourself with an file-open-dialog.

To start the update procedure, click “Update”. While update do **not plug out** the cable from the PLC or turn off the power supply (The cable will lost all data)!

Handbook Cable & Adapter

If the update is breaking before finished, it could be that the MPI-Cable displays in the first line of the LCD „Load 1.50“ and in the second line „CheckUpd“. Close the MPI-Cable-Manger and restart it. After “check version” (which could time about 30 seconds) and following „Update“ the broken update is restarted and finished.

9.4 Teleservice

9.4.1 Telephone-Book

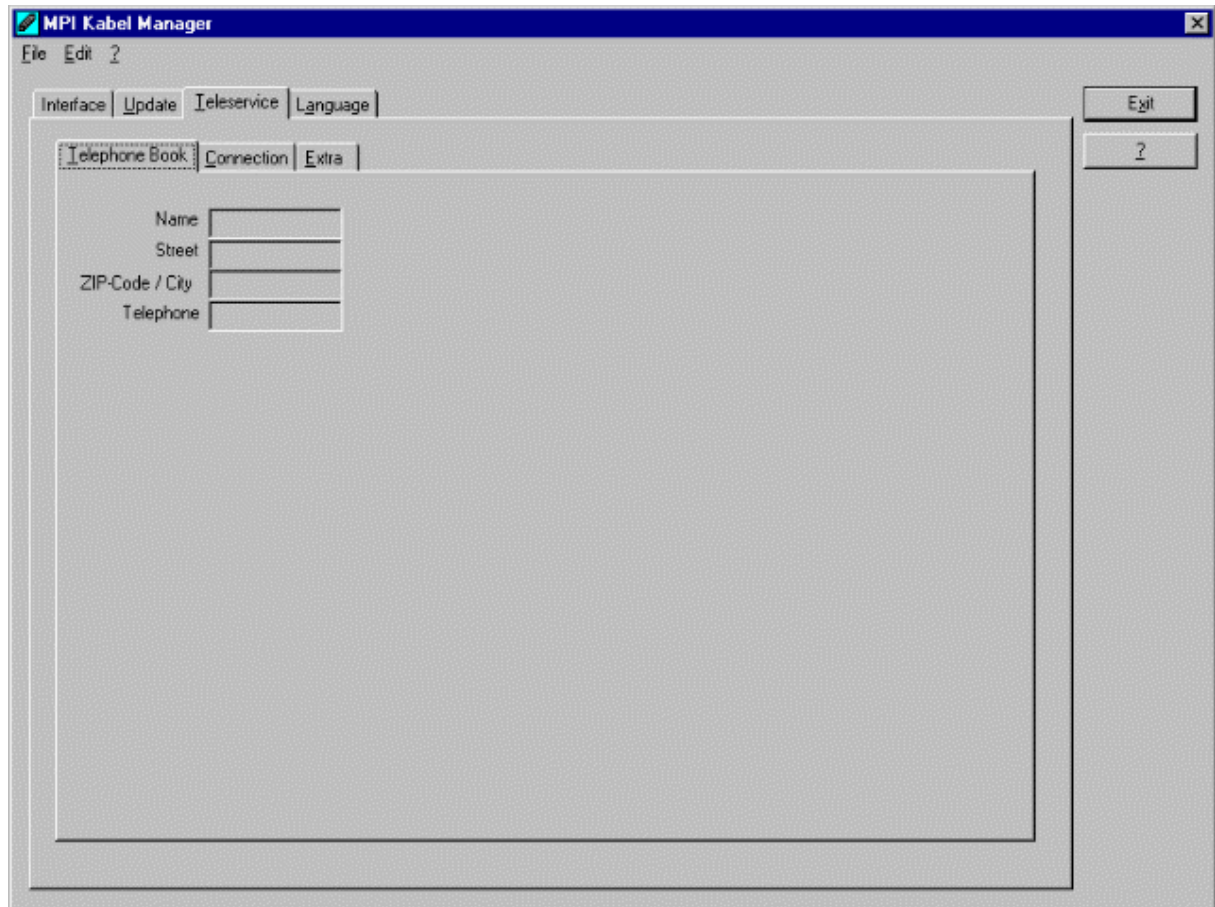

In this dialog you could define new elements or edit/erase existing elements in your telephone-book.

You could edit the following data:

Name for the connection (these are displayed at connection)

Street

ZIP-Code / City

Telephone-number

9.4.2 Connect

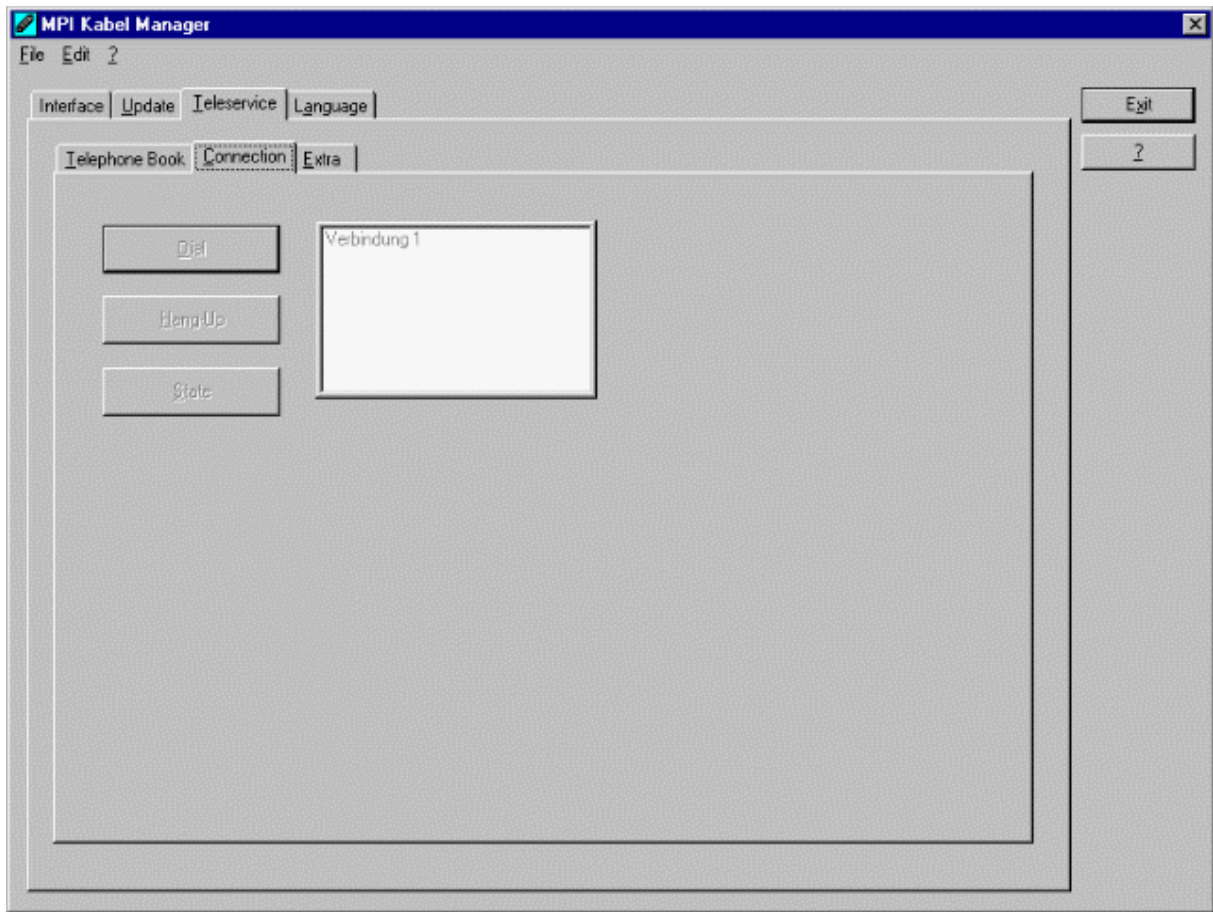

In this dialog the connection to another modem with a MPI-cable connected is started.

Choose on the right side the named connection, then press “**Connect**” to establish it.

With “**Hang-Up**” you could stop an existing connection.

With the button “**State**” the state of the connection is displayed at the lower side of the dialog.

9.4.3 Extra

After selecting the tab „TeleService“ the following dialog is displayed:

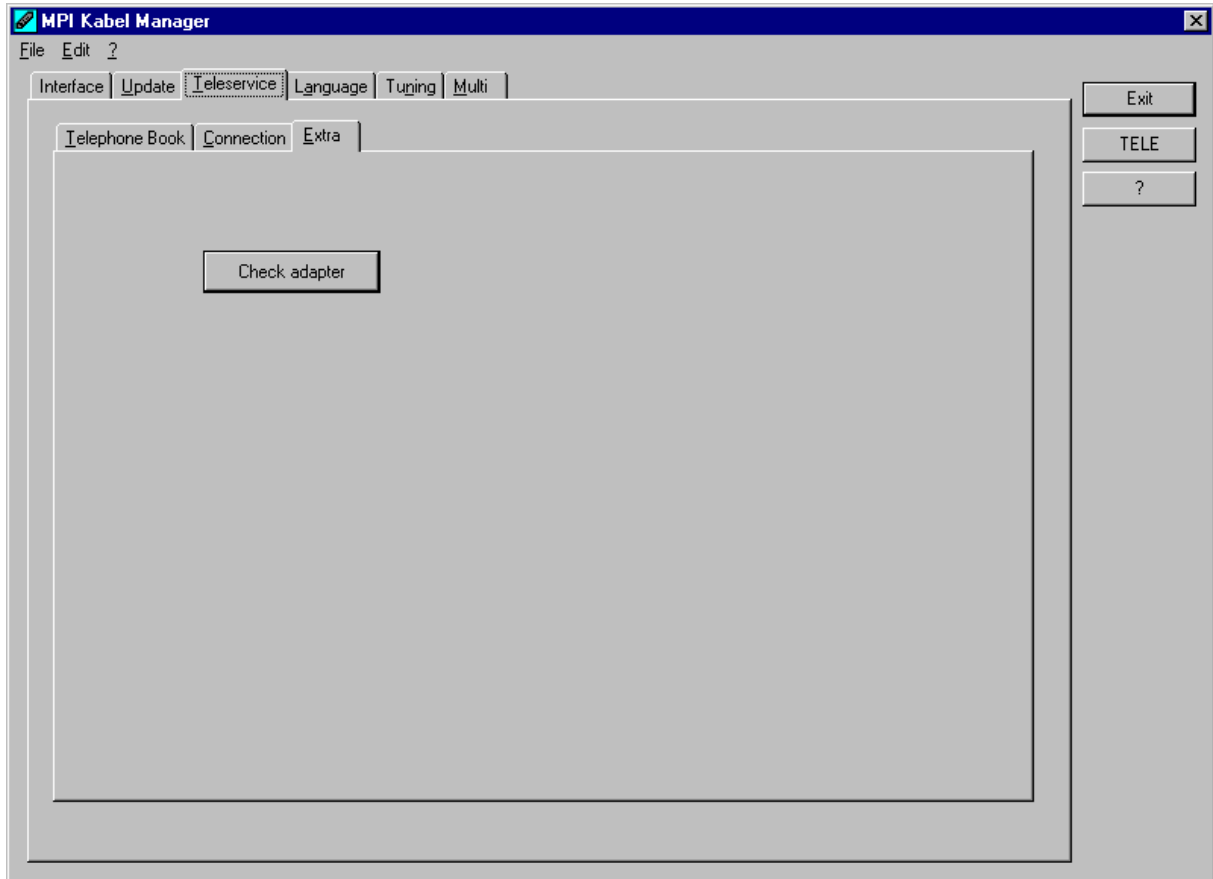

If you press the button „Check adapter“ the cable is checked and the state-information is read from the cable. This information is displayed in the following dialog:

Handbook Cable & Adapter

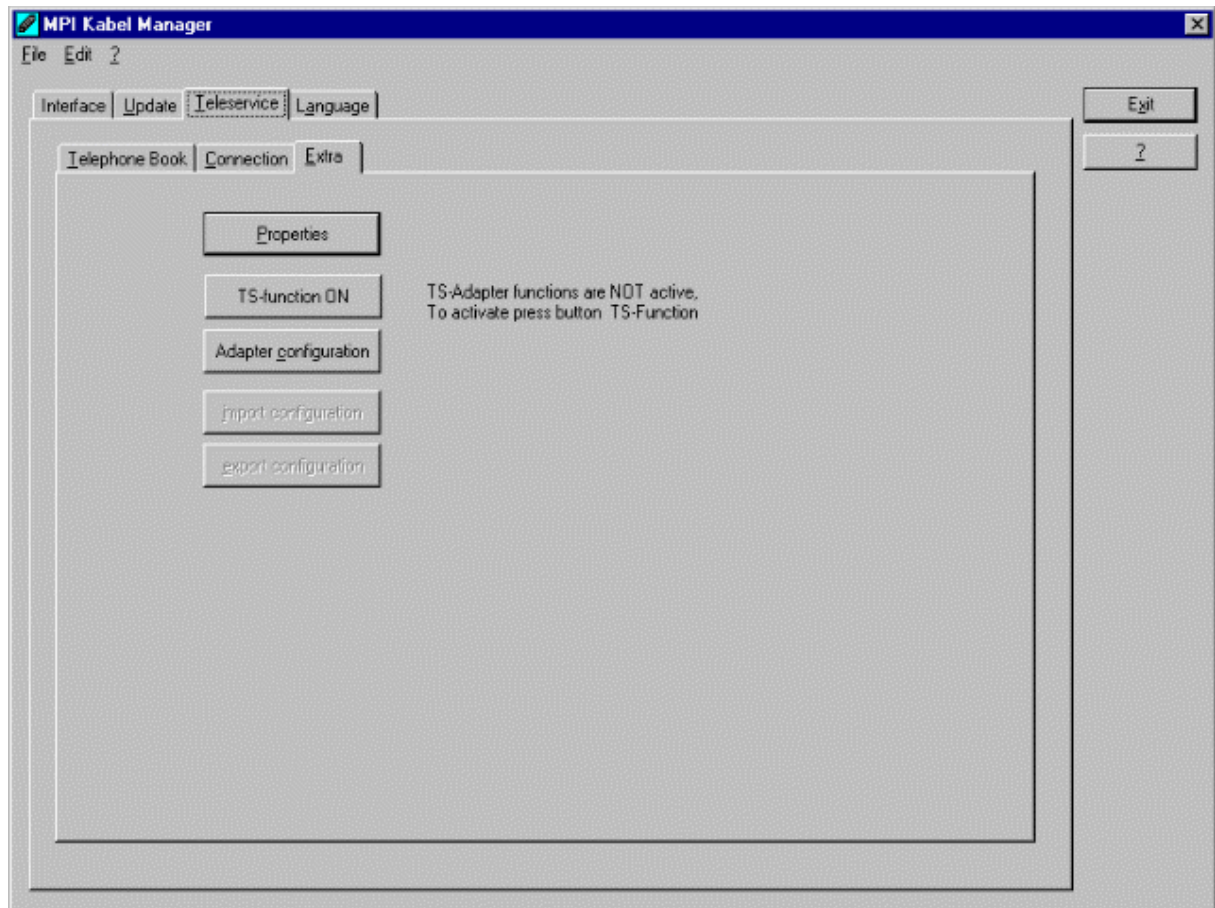

In this dialog, all configuration to the TS-adapter is done.

The actual state of the MPI-cable is displayed right of the button **“TS-function”**, where the following 4 possible messages could appear:

“TS-Adapterfunction is NOT active. To activate press TS-function”

The MPI-cable acts like an PC-Adapter. There will no answer for TS-specific protocols, the attached modem will not initialised and the baud-rate to the PG/Modem is not fixed. The baud-rate is detected automatically.

“TS-Adapterfunktion is ACTIVE. To disable press TS-function ”

The MPI-cable acts like an TS-Adapter. There will an answer to TS-specific protocols, the adapter could now configured. An attached modem will be initialised and the baud-rate to the modem is fixed.

“SNDERR” or “RCVERR”

There is a communication error at sending or receiving data from the MPI-cable. Disconnect the MPI-cable from the power supply (PLC). Change to the tab **connect** and after that back to **extra**. If the problem remains, check the connection to the MPI-cable, especially the COM-port in the dialog interface.

9.4.3.1 Setup

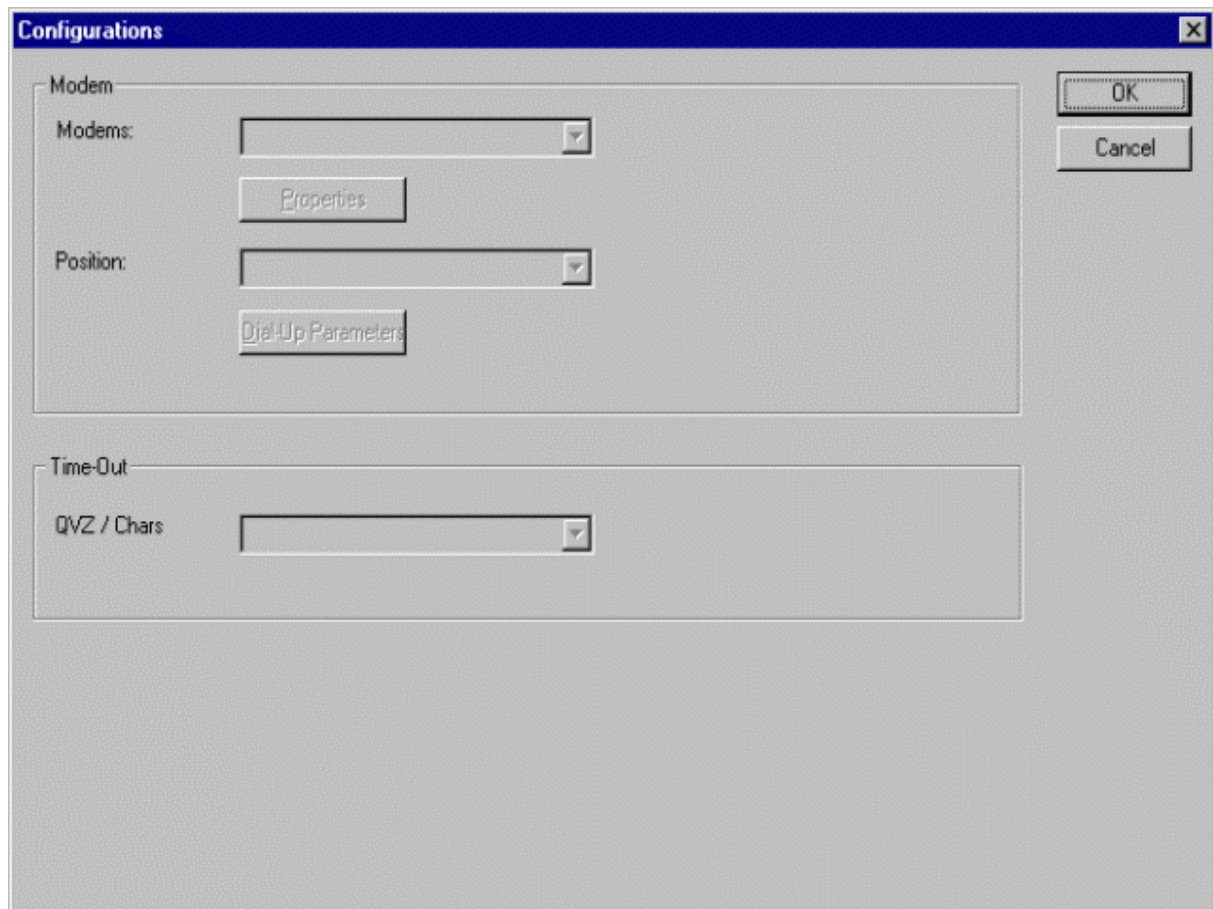

In this dialog the used modem, the position of the modem and the timeout of the connection could be configured.

9.4.3.2 TS-function

With this button you select the function of the MPI-cable as TS- or PC-adapter. Right of this button the actual state of the MPI-cable is displayed. The state of the MPI-cable could also be detected on the LCD-display, if the state is PC-adapter in the middle of the first line „PG“ or „Pg“ is displayed. When the state is TS-adapter you could see in the middle of the first line on the LCD-Display „TS“ or „Ts“.

9.4.3.3 Adapter configuration

9.4.3.3.1 Network

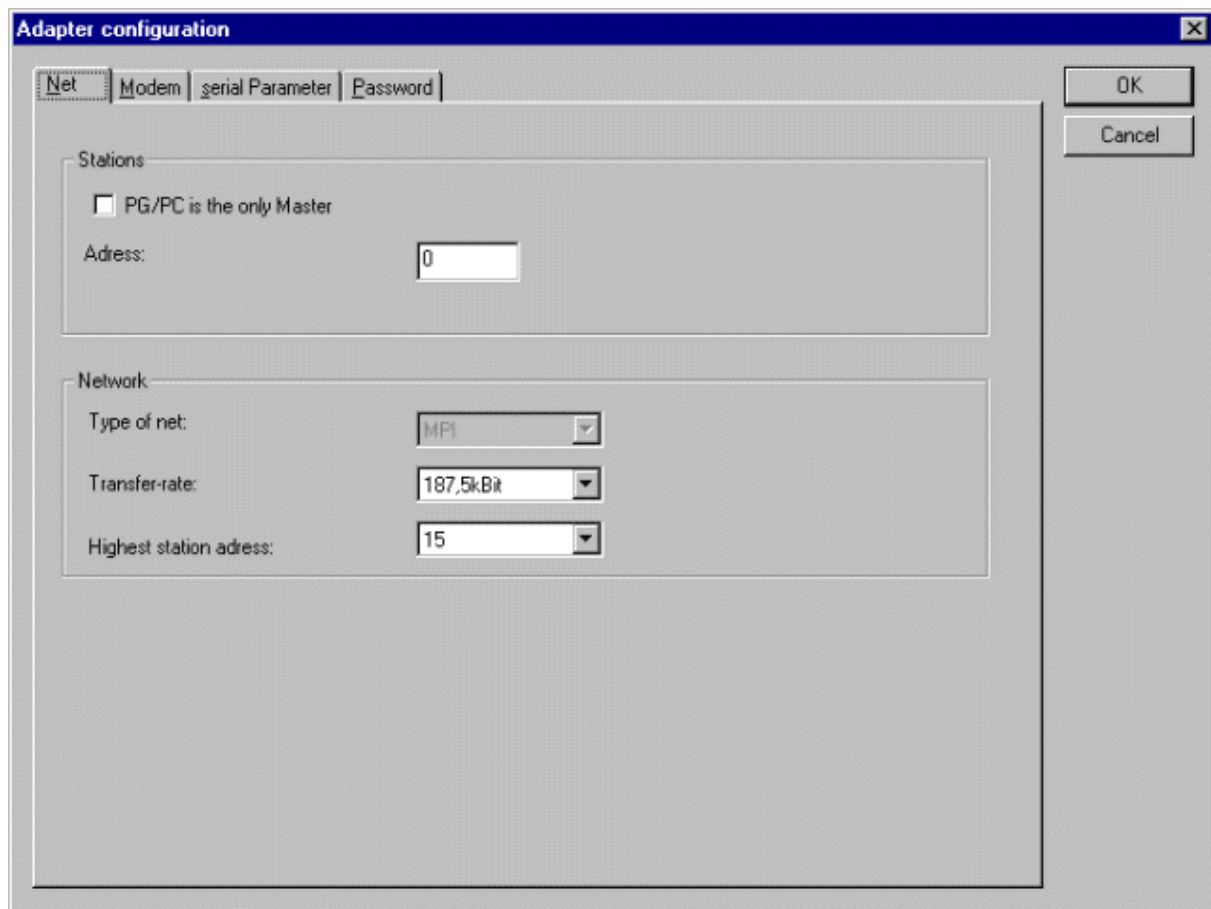

station-related you could configure if

The TS-Adapter is the one and *only master* in the MPI-bus (he must talk with all passive devices)

Which *local station-address* is used for the TS-Adapter. Please consider that a programming device has normally the number 0, operator panel have 1, PLC's use 2, FM/CP's 3 etc.

Please: Never use the same station-number for 2 different stations !

Network-related you could configure:

The *transfer-speed* on the MPI-bus (for now configure 187,5kBaud or 19,2kBaud!)

The highest station-address in the bus (the less you use, the more performance on the MPI-bus, must be corresponding with the configuration in the PLC's)

9.4.3.3.2 Modem

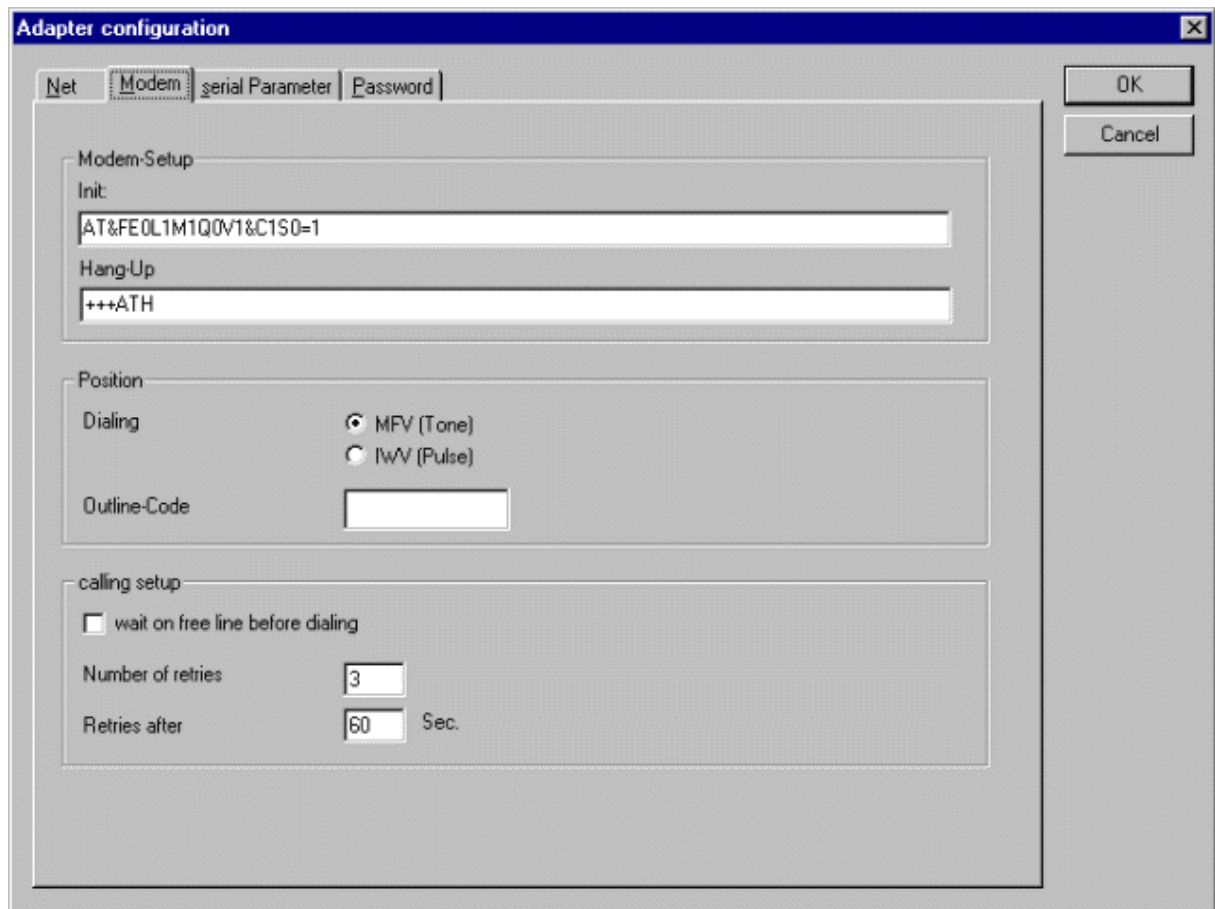

In this dialog you could configure the modem-related setup.

The *Init-String* is composed out of several commands to the modem:

AT	start command
&F	use factory settings
E0	echo off
L1	loudness of speaker is low
M1	speaker is on at connection
Q0	enables result codes to the DTE
V1	enables long-form (verbose) result codes
&C1	DCD follows the state of the carrier
S0=1	automatic connection after 1 ring

Handbook Cable & Adapter

The *Hang-Up-String* is composed of 2 elements:

+++ change to command-mode

AT start command

H hang-up connection

There are 2 possible calling technics:

MFV tone, the telephone-number is transfer by several frequencies

IWV pulse, the telephone-number is transferred with the count of several pulses on the line

When you must a pre-call to establish a call outside your company, you could define it at *Outline code*.

When the modem should wait for a free line, so you should set the corresponding checkbox.

At *number of retries* you could configure the number of retries for a connection before the call is stopped.

When using a retry you could choose the seconds which the application should wait between calls.

9.4.3.3.3 Serial parameter

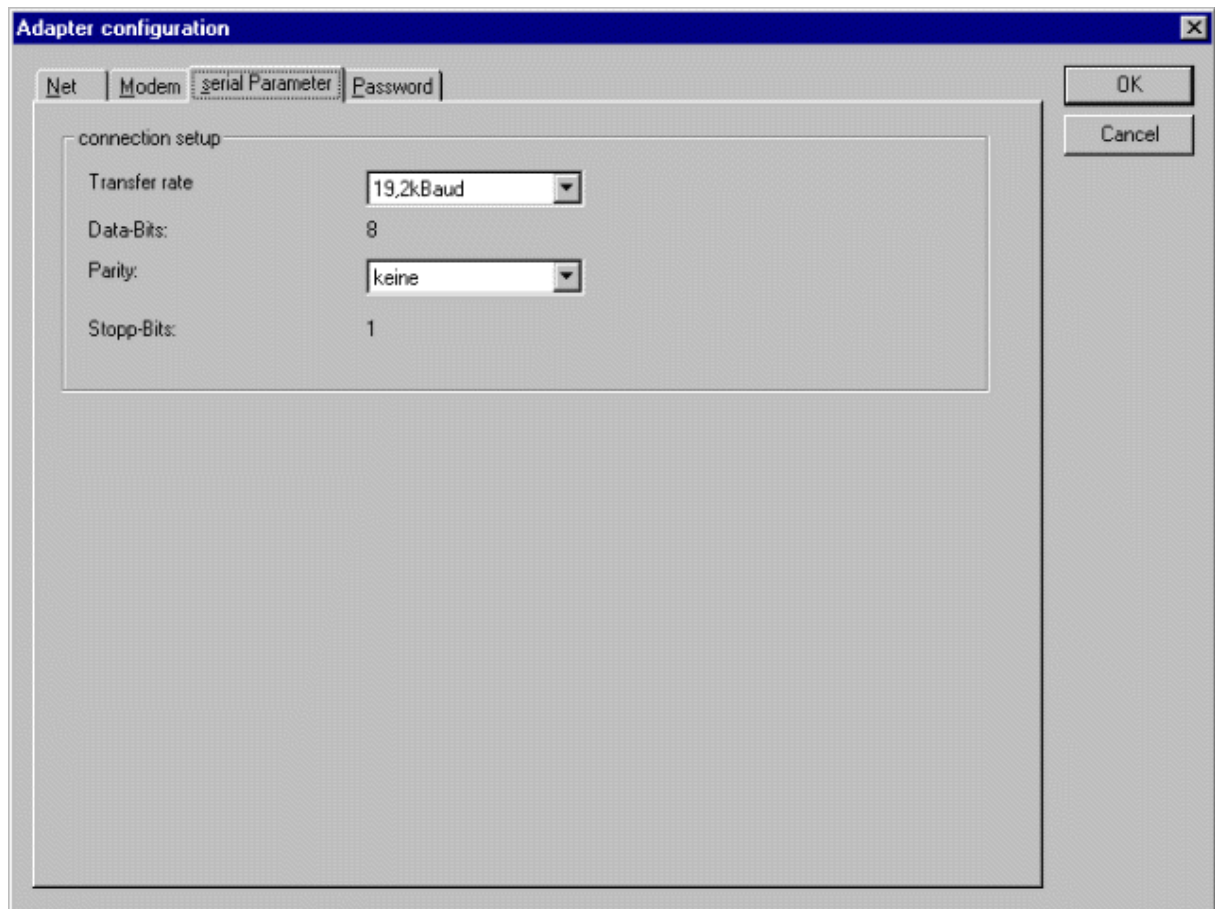

In this dialog the transfer-rate between modem and TS-Adapter is selected.

The transfer-rate could chosen between those values:
2400, 4800, 9600, 19.2k, 38.4k, 57.6k, and 115.2kBaud

The **Parity** could be chosen, but this is modem-dependant because some modems could not transfer the parity-bit:

None (no parity-check)

Odd (the numbers of one-bits are odd)

Even (the numbers of one-bits are even)

Handbook Cable & Adapter

9.4.3.3.4 Password

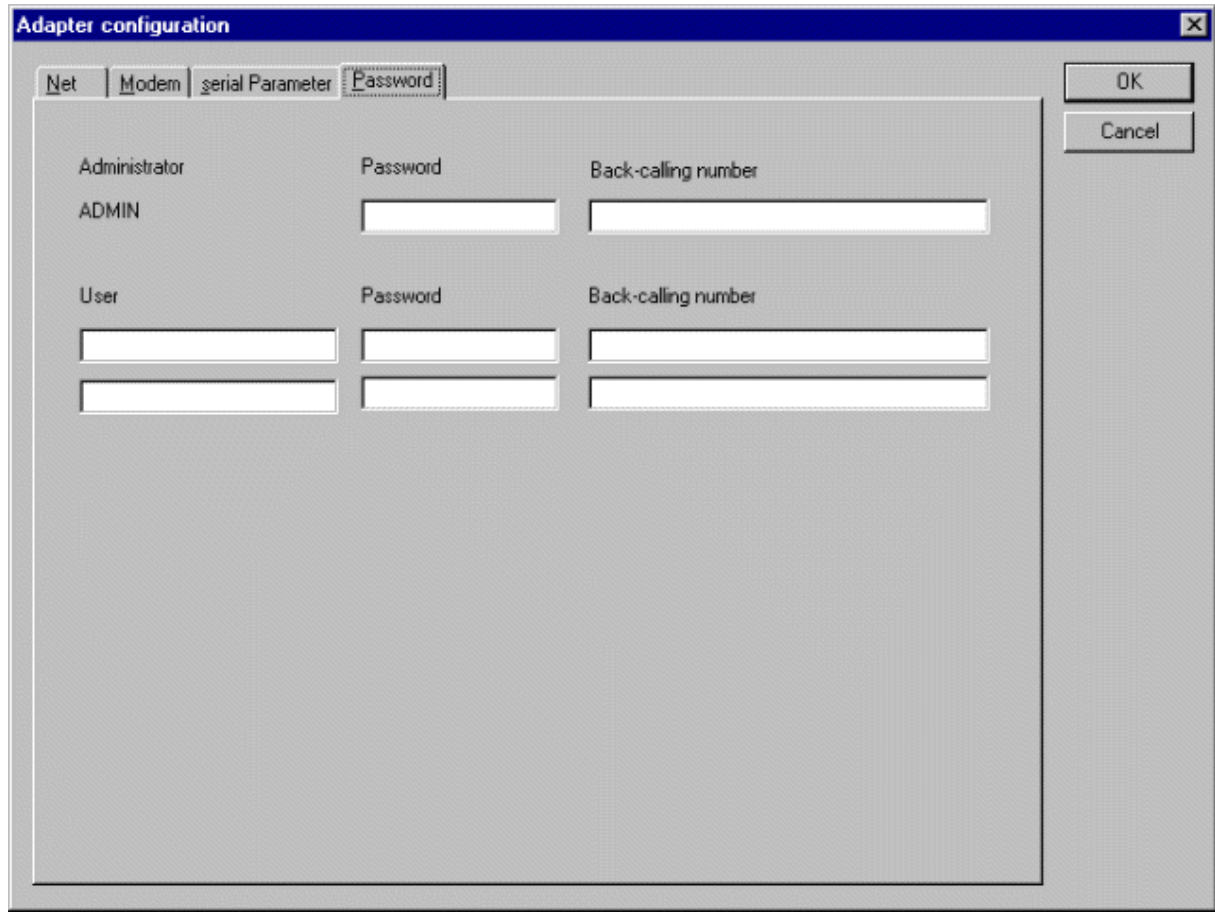

The access over a telephone-line on the PLC could be configured in this dialog..

The administrator could change the configuration over a telephone line, where the 2 user could not change the configuration.

The user-Name is max. 8 chars long. Every user and the administrator could use a password which is used to log into the PLC over a telephone-line. After 3 wrong retries the connection is hanged up, so you must call again (Not so with an original TS-adapter). After changing the password for one user/administrator you must re-type it again correctly before it is used.

In call-back-number you could define a telephone-number which is used for call-back from the TS-adapter. After you connect with the TS-adapter, you are asked for your user-name and password. When the correct password and user-name is transferred, the connection is hanged-up and the TS-adapter is calling back this configured call-back-number.

Handbook Cable & Adapter

9.4.3.4 GSM / ISDN / SMS

9.4.3.4.1 GSM-Modem

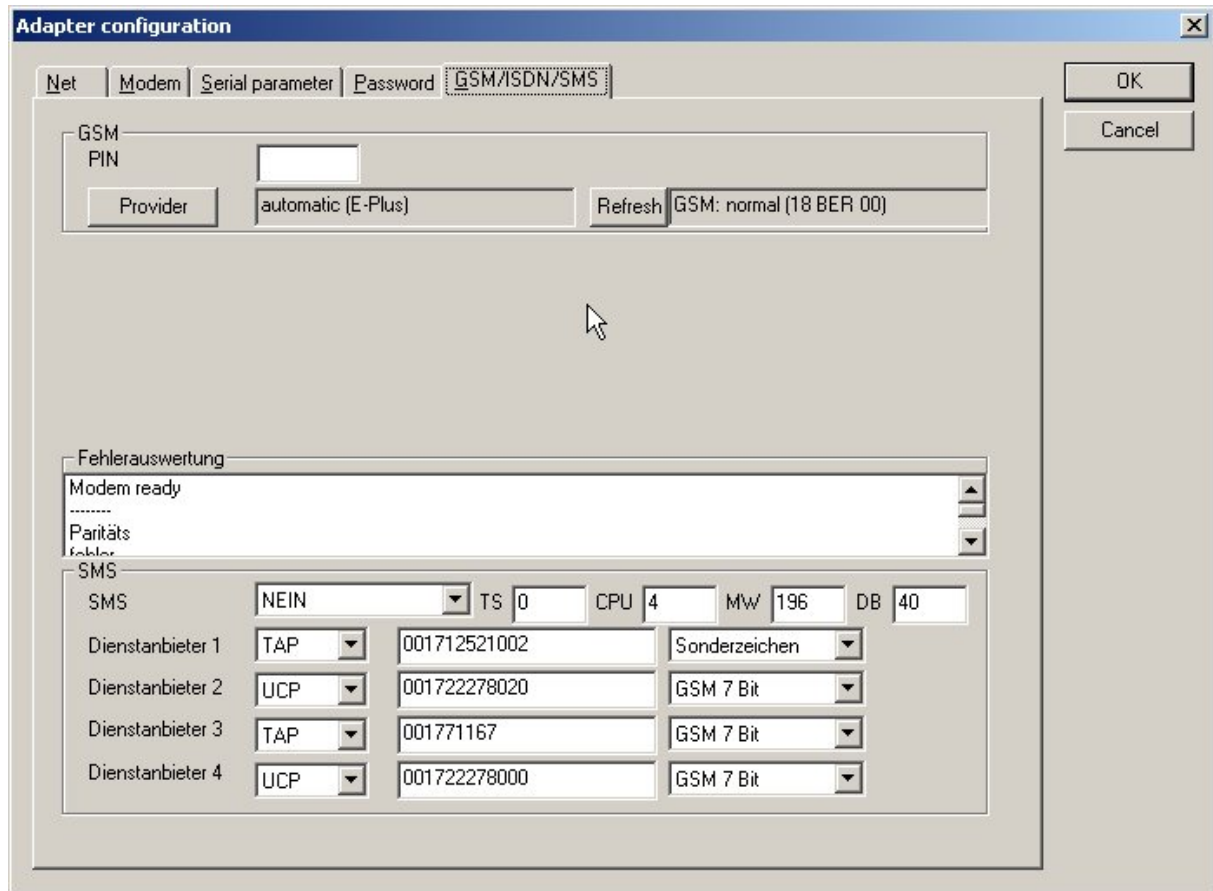

PIN PIN-Number of the SIM-Card, up to 8 numeric chars, (only for TELE-SERVICE GSM).

With the Button „Provider“ the provider could be chosen.. Reading of the list of providers could be elapse more than a minute. At end the possible provider are listed for selection. With „Automatic“ the GSM-Modem tries to connect automatically to a provider.

On the right side of the button, the actual used selection is displayed.

Display	Description
Automatic	The Provider is automatically searched and selected from the GSM-Modem.
Manual	The Provider is selected manually from the GSM-Modem
no network registered	No connection to the GSM-network, the receive-quality is too bad
set format	The format of the provider is set
manual/ automatic	The modem tries to select manually the provider, if this fails an automatic search is done
unknown	Unknown response from GSM-Modem

Beneath the button „Refresh“ which reads from the Modem the receive quality, the quality is displayed.

Display	Description
Unknown	Unknown state of the GSM-network
no registration:	The modem is not registered in the GSM network, no provider found
registration denied:	Registration in the GSM-network is denied
Search network:	In Search for a GSM-Provider
GSM:	Attached to GSM
GSM(ROAMING)	Attached to GSM, but with a Roaming-Partner. This could lead to high costs!

Handbook Cable & Adapter

The Receive Quality is displayed, also as value together with the bit-error-rate.

Value	Description
99	No network, no receive
00	Very,very bad receive-quality
01	Very bad receive-quality
02 bis 09	Bad receive-quality
10 bis 17	Medium receive-quality
18 bis 25	Normal receive-quality
26 bis 30	Good receive-quality
31	Best receive-quality

9.4.3.4.2 ISDN-Modem

The screenshot shows the 'Adapter configuration' dialog box with the 'GSM/ISDN/SMS' tab selected. The 'ISDN' section includes a 'Type' dropdown set to 'EuroISDN NET3' and a 'Protocol' dropdown set to 'X.75'. Below this is a 'Fehlerauswertung' (Error evaluation) section with 'Modem ready' and 'Paritätsfehler' (Parity error) indicators. The 'SMS' section includes fields for 'NEIN', 'TS 0', 'CPU 255', 'MW 65535', and 'DB 65535'. Below these are four rows for 'Dienstanbieter' (Service providers), each with a 'KEIN' dropdown, a text field, and another 'KEIN' dropdown. The dialog has 'OK' and 'Cancel' buttons on the right.

Type Choose the type of the ISDN-network switch:

AT&T 5ESS

Nothern Telecom DMS-100

EuroISDN NET3 (Standard)

INS64

US NI-1

VN4

DN/MSN Directory Number resp. Multiple Subscriber
Number

Is used for both ISDN-channels. When using the
number 255 no DN/MSN is used.

Protocol Choose the transfer-protocol-type:

Modem-like

V.120

X.75 (Standard)

ML-PPP

SoftBonding

HDLC

CLEAR

Handbook Cable & Adapter

9.4.3.4.3 Analog-Modem

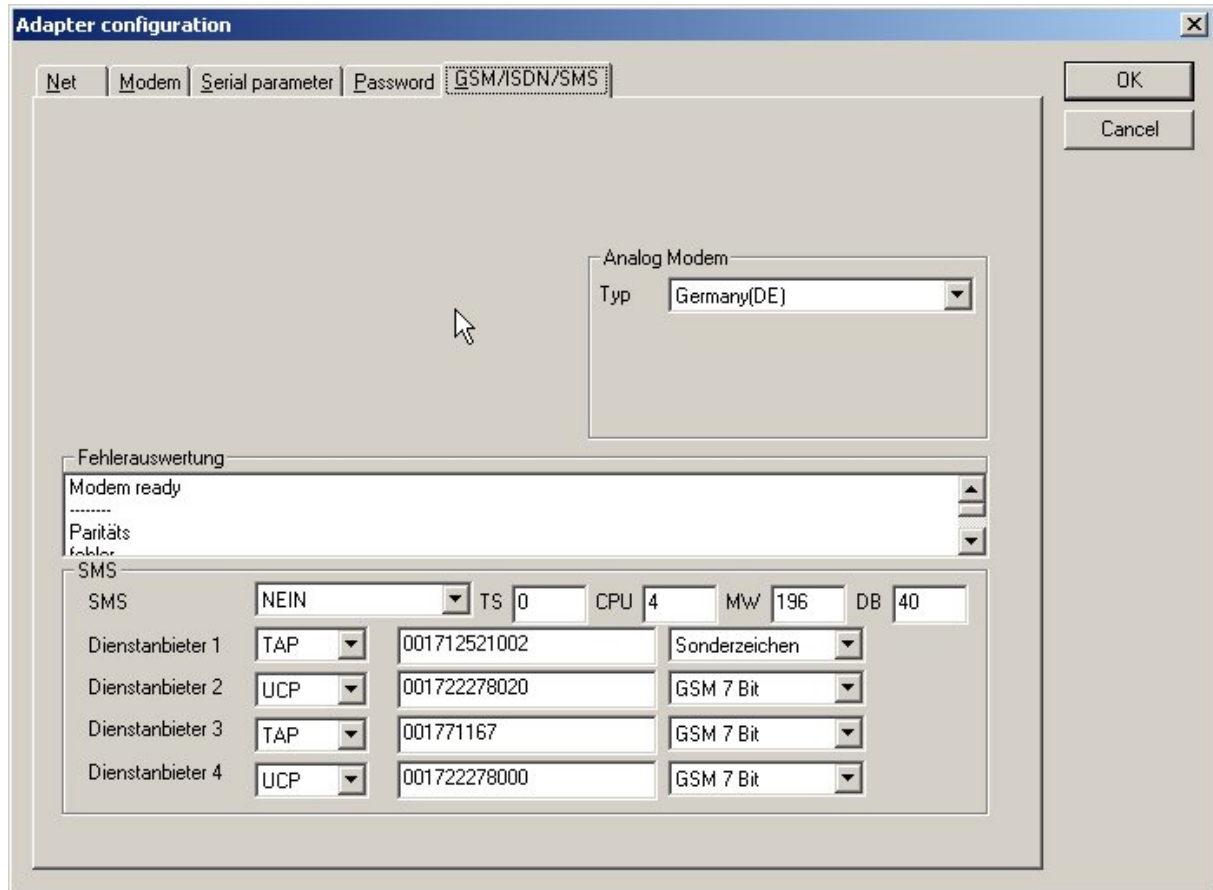

You could choose the Location of the Modem.

9.4.3.4.4 Messages

The possible error conditions for the modem, mpi-bus-problems or other problems are displayed in this text-field. Firstly, the modem-related information is shown:

Message
Modem ready
Modem error
No dialtone detected
no answer from modem
Modem detects ring
End of Connection
Modem connected
No carrier detected from modem
Phone-line or telephone busy

Phone-number is blacklisted in modem
Phone-number delayed. Access denied for 1 minute.
Fax-call detected
Data-call detected
unknown error
The selected direct-access-number not configured
The configured PIN-Number is wrong for the inserted SIM-Card
The SIM-Card is not or wrong inserted or the SIM-Card is a 5V Type

Following the possible MPI-Bus error-messages

Message
MPI/Profibus-Configuration erroneous
Timeout at MPI/Profibus detach from device.
The local station-address is used twice in the MPI/Profibus.
A20/M20/TC35 Modem
The MPI/Profibus is not correctly configured
The HSA is not configured optimal
The MPI/Profibus-Baudrate is not detectable
Overflow in the internal MPI-Readbuffer
Overflow in the internal LAN-Readbuffer
Overflow in the serial Buffer
The selected MPI/Profibus-Baudrate is wrong
Overflow in internal LAN-Writebuffer
LAN-Recieve-Error
LAN-Send-Error
The PD-Numberr is wrong
The transfered SAP is wrong/unknown
ErrCode 01: The Destination address (XXX) of a Stateprotocol > 127 detected.In the MPI/Profibus-Bus there are no stations possible which stationnumber is

greater as 127. (FC=YYh)
ErrCode 02: At state-protocol the Source-Adress is detected as 127 . This is the Broadcast-address which is not possible.
ErrCode 03: Es wurde ein Statusprotokoll empfangen dessen Zieladresse (XXX bzw. YYY) gar nicht im MPI-Bus vorhanden ist. (FC=ZZh)
ErrCode 04: Es wurde ein Statusprotokoll von XXX empfangen, in dessen Funktionscode (YYh) das Bit 7 gesetzt ist. Dieses Bit ist per Spec. auf 0 zu setzen.
ErrCode 05: Es wurde ein Statusprotokoll von XXX empfangen, der Funktionscode (YYh) bedeutet aber das der Teilnehmer nicht bereit ist in den Bus zu gehen.
ErrCode 06: Unbekannter Funktionscode von XXX im Statusprotokoll empfangen (FC=YYh)
ErrCode 11: Es wurde ein Datenprotokoll von einem nicht im Bus befindlichen Teilnehmer (XXX) an das Kabel gesendet. Zum Senden von Daten muß aber der Teilnehmer das Token erhalten. (SSAP=YYh, FC=ZZh,Länge=UUU)
ErrCode 12: Datenprotokoll mit Source-adresse 255 (Broadcast) ist unsinnig (CPU=XXX,SSAP=YYh,FC=ZZh,Länge=UUU)
ErrCode 13: Es wurde ein Datenprotokoll von einem nicht im Bus befindlichen Teilnehmer an das Kabel gesendet. Zum Senden von Daten muß aber der Teilnehmer das Token erhalten. (CPU=XXX,SSAP=YYh,FC=ZZh,Länge=UUU)
ErrCode 14: Bit 7 im Funktionscode gesetzt, laut Spec. Muß selbiges 0 sein. (CPU=XXX,SSAP=YYh,FC=ZZh,Länge=UUU)
ErrCode 15: Obere 4 Bit des Funktionscode im empfangenen Datenprotokoll sind falsch/unbekannt. (CPU=XXX,SSAP=YYh,FC=ZZh,Länge=UUU)

<p>ErrCode 16: Unbekannter Funktionscode an das Kabel gesendet. (CPU=XXX,SSAP=YYh,FC=ZZh,Länge=UUU)</p>
<p>ErrCode 17: Ziel-SAP sind bis 3Fh bei Datenprotkollen definiert.(CPU=XXX,SSAP=YYh,FC=ZZh,DSAP=UUh)</p>
<p>ErrCode 18: Quell-SAP sind bis 3Fh bei Datenprotkollen definiert. (CPU=XXX,SSAP=YYh,FC=ZZh,SSAP=UUh)</p>
<p>ErrCode 19: Empfang eines Datenprotkolls mit Ziel-SAP=0, Verbindungsaufbau von anderem Bus-Teilnehmer mit unserem Kabel. (CPU=XXX,SSAP=YYh,FC=ZZh,DSAP=UUh)</p>
<p>ErrCode 1A: Teilnehmer senden Daten an unser Kabel welche als Quell-SAP 0 haben, das heißt der Teilnehmer hat vorher keinen Verbindungsaufbau gemacht oder die ausgehandelte SAP verloren. (CPU=XXX,SSAP=YYh,FC=ZZh,DSAP=UUh)</p>
<p>ErrCode 1B: Datenprotokoll empfangen, Daten-funktionscode unbekannt. (CPU=XXX,SSAP=YYh,FC=ZZh,DFC=UUh)</p>
<p>ErrCode 1C Datenprotokoll empfangen, Daten-funktionscode unbekannt. (CPU=XXX,SSAP=YYh,FC=ZZh,DFC=UUh)</p>
<p>ErrCode 1D: Es wurde ein StatusProtokoll mit gesetzten Fehlercode empfangen. (CPU=XXX,FPGA=YYh,RAM=ZZh)</p>
<p>ErrCode 1E: FPGA hat einen interrupt ausgelöst obwohl keine Daten vorhanden. (SD1=XXh,SD1=YYh,CPU=ZZZ,FC=UUh)</p>
<p>ErrCode 20: unbekanntes Protokoll bei PPIMUltimaster. (FC=XXh,Länge=YYY)</p>
<p>ErrCode 21: unbekannte Baudrate bei PPIMultimaster (Baudrate=XXh)</p>

After that additional hints are displayed.

9.4.3.4.5 SMS-Processing

SMS Switches Processing OFF / Only Receive /

Handbook Cable & Adapter

Only Send / Receive and Send.

Attention: **before setting ON check**

Configuration, after activating the device will go into the MPI-BUS and tries to connect to the defined PLC. **Receive of SMS only with TELESERVICE-GSM**

- TS local station-address (should not be used twice in the MPI/Profibus!)
- CPU from this station-address the Flagword and Data-block is accessed for communication
- MW communication-flagword (the first byte is the command, the second is the state). Use even operand-addresses.
- DB communication-data-block.
- Provider 1/2/3/4 Configure the SMS-Provider to use, including type, phone-number and char-code.

9.4.3.5 Import configuration

With this button you could import the parameter from an ASCII-file. This file is compatible to the original file-format.

9.4.3.6 Export configuration

With this button you could export the parameter to an ASCII-file which has the same file-format as the original.

9.5 Tuning

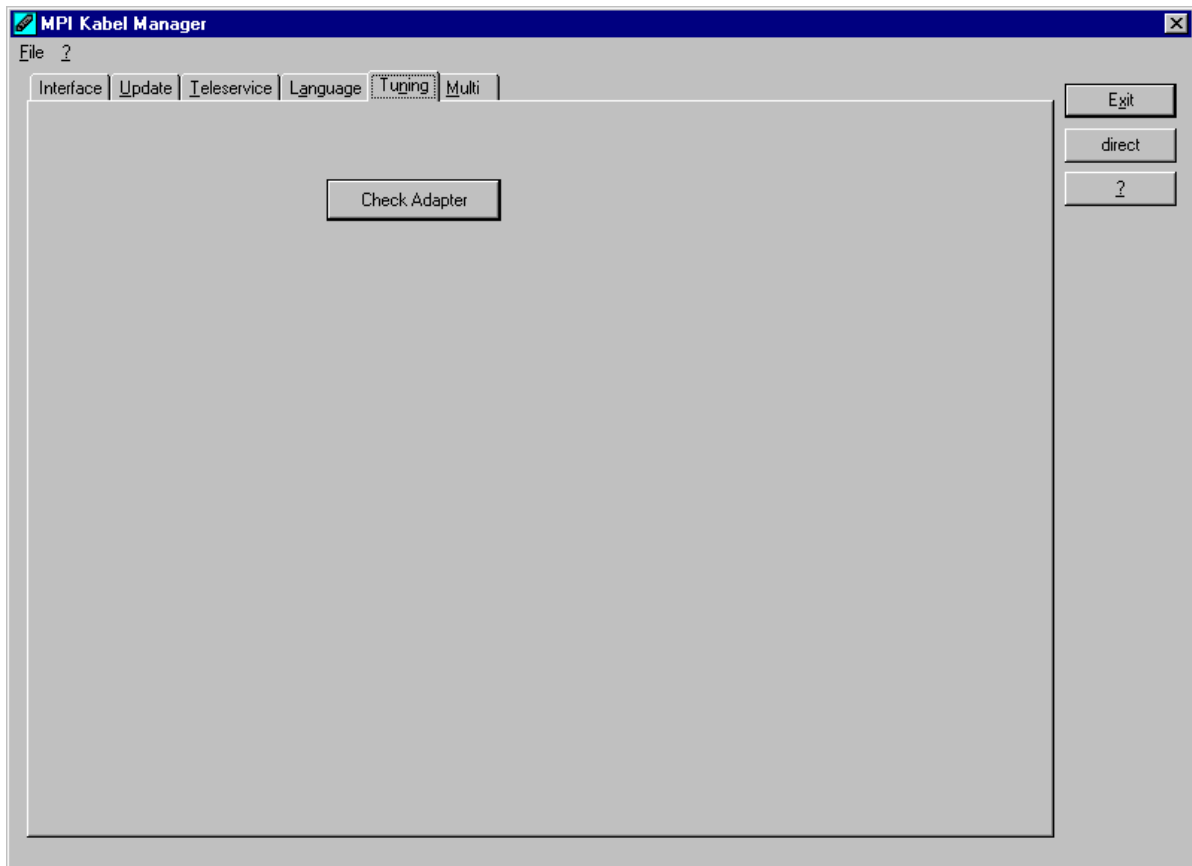

This tab is only used in some special cases. If you press the button „Check Adapter“ the cable is connected und after that the following dialog is displayed:

Handbook Cable & Adapter

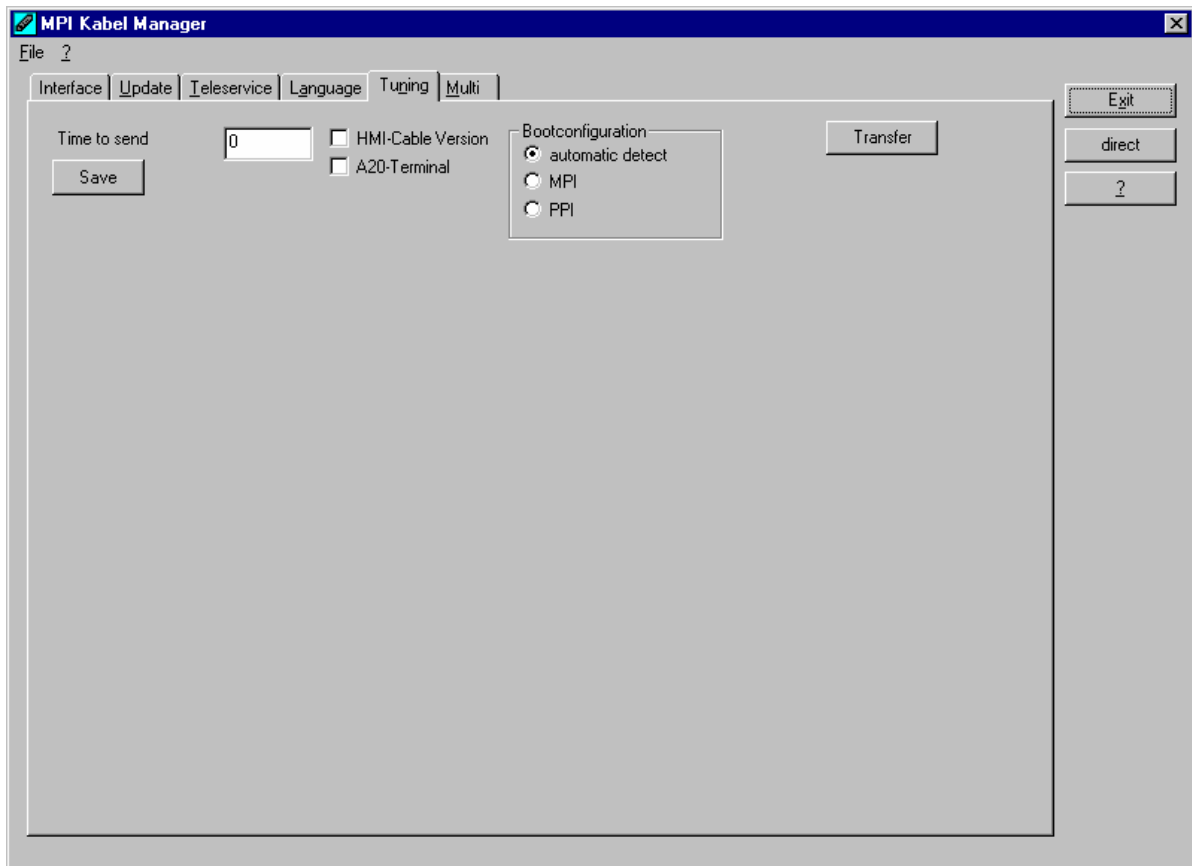

There are the following configuration possible, they will be transferred to the MPI-Cable by pressing the button „Übertragen“. The configuration is saved permanently in the Flash-ROM:

Time to send

At ProTool RT the communication could break down, because the MPI-Cable is transferring the answer-protocol to fast. In this property you could insert a time in 0.1ms ticks. Insert at first 300, to great values are preventing the communication.

HMI-Cable-Version

Some Touch-panels have the problem, that when they get a wrong version-information they never retry to connect (and then the correct version is transferred). In this case

the HMI-version-information could be transferred immediately.

A20-Terminal

When using the A20 or M20-Terminal, the control-lines on the serial port are not used., in that case the tele-service-function is not working. With this property the control-lines are no longer used and therefore the A20/M20 can communicate over tele-service.

Bootconfiguration

Normally the MPI-Cable automatically selects the correct bus-type, no changes are needed. In special-cases the MPI-Bus could be selected as PPI. For example: This application and the PLC are powered on at the same time. The application is communicating immediately with the cable, the PLC is booting, in this case the MPI-Bus is not driven. The MPI-Bus is erroneous, so no communication is starting. If this occurs you could choose, that the cable is working as MPI-Adapter only..

Language

You could select the language which is used from the cable (German or English)

9.6 Connection of a TS-Adapter

The connection of the TS-adapter is done like shown in the next picture:

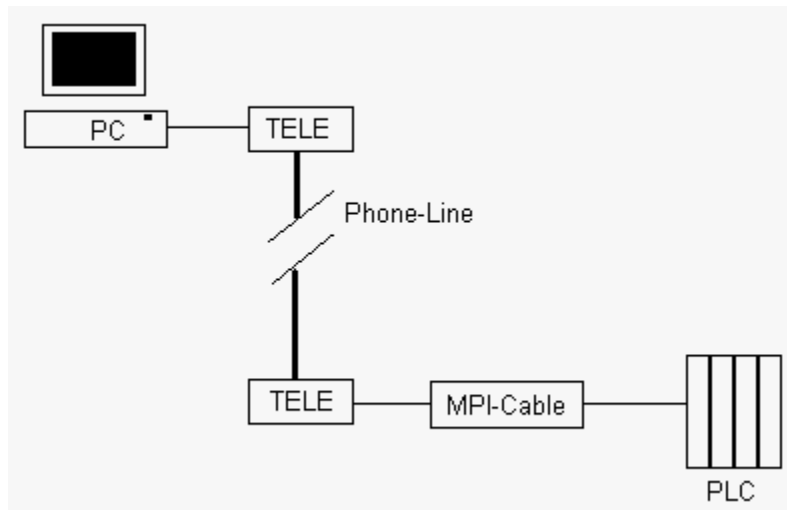

The adapter which is used between TS-adapter and modem could be bought as an attachment from us. The pinning of this adapter is:

MODEM	MPI-cable
9pol.Sub-D, male	9pol.Sub-D, male

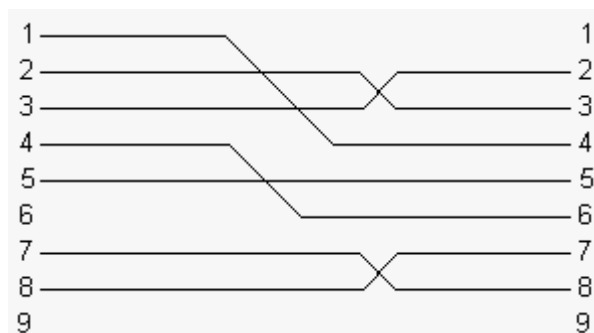

The shield is connected at both Sub-D metal casing

9.7 Update over Tele-Network

The update of versions before V1.41 from the **green** cable is **not** possible with this software! The green cable must be changed at our company in hardware!

The connection of the Tele-Network looks like shown in the next picture:

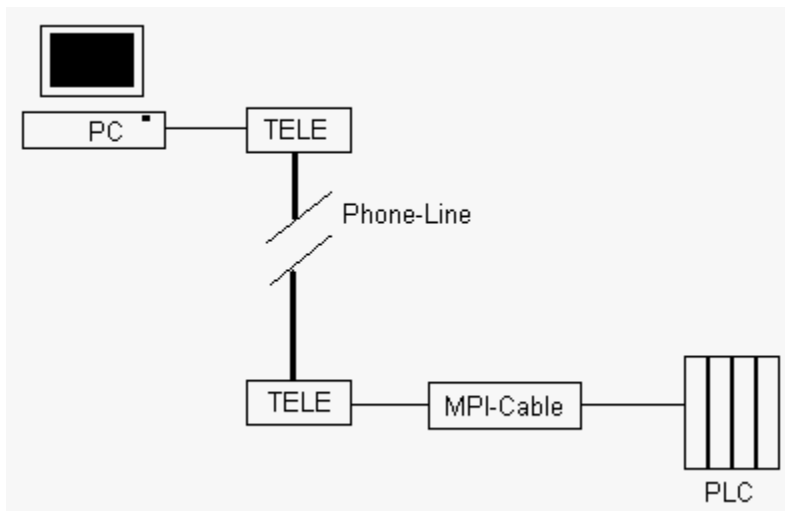

To perform an update over the telephone line you should do the following Steps:

Connect the two Tele-Network-modems (make a call)

At the PG-Tele go to menu „special/transparentmode“

Define the source-COM as: **PG,19200,8,O,2**

Define the destination-COM as: **AG,19200,8,O,2**

Go to a DOS-Box or under MS-DOS in the directory where the MPI-cable-manager is located

Handbook Cable & Adapter

Start the batch file with the serial COM-Port as parameter:

LD.BAT	1	for COM1
LD.BAT	2	for COM2

The Update has 3 Steps, do **not** disconnect the phone-line while the update is in progress (it causes the lost of all data)!

The end of the update is signaled !

9.8 Connecting the A20 Terminal

The A20 Terminal (M20) is a GSM - Modem/Handy which transfers data over the GSM - network. To connect to a A20 terminal over the tele-service you must do the following:

- 1.) The operating system of the MPI-cable must **V1.67ff**
- 2.) The operating system of the A20 Terminal must **V4.2ff**
- 3.) The MPI-cable must configured in A20-Terminal mode. In the tab „Tuning“ setting the checkbox „A20 Terminalmode“ and transferring do the job.
- 4.) The modem-init-string must be changed (erasing „&C1“):

From: AT&FE0L1M1Q0V1**&C1**S0=1

To: AT&FE0L1M1Q0V1S0=1

- 5.) The TeleService - software V5.0ff must be Installed
- 6.) In S7-Manager (V5.0ff) under „Extras/PG-PC Interface“ must the driver „TS-Adapter“ be selected
- 7.) In the properties must be selected the „modem“.
- 8.) In S7-Manager choose the menu point „Extras/TeleService“.
- 9.) In the TeleService - Manager under „Extras/Properties“ the „Timeout QVZ/Chars“ must be „5000/4000ms“.
- 10.) Between A20 Terminal and MPI-cable must be a TS – Adapter connected (**no** standard – changer !).

9.9 Siemens-Original-Software and MPI/PPI/HMI/TS-Adapter with 115200 Baud

To use the higher baud-rates over 38,4kbaud on the PC-side the following dependencies must be present:

- 1.) The MPI-Adapter needs the operating system **V1.77** or higher (update with MPI-cable-manager)
- 2.) The S7-software needs **V5.0 with ServicePack 3** or higher from Siemens)
- 3.) The driver PC-Adapter“ in the S7-Manager under „Extras / PG/PC-Interface“ should be selectable. (installation of this driver)

The MPI-Speed-driver must be installed (on our homepage at www.tpa-partner.de, in MPI-cable)

After that the driver „MPI/PPI/HMI/TS - Adapter 57k6/115k2 Baud“ in „Extras / PG/PC-Interface“ is selectable and under the properties of this driver you could choose the higher baud rates:

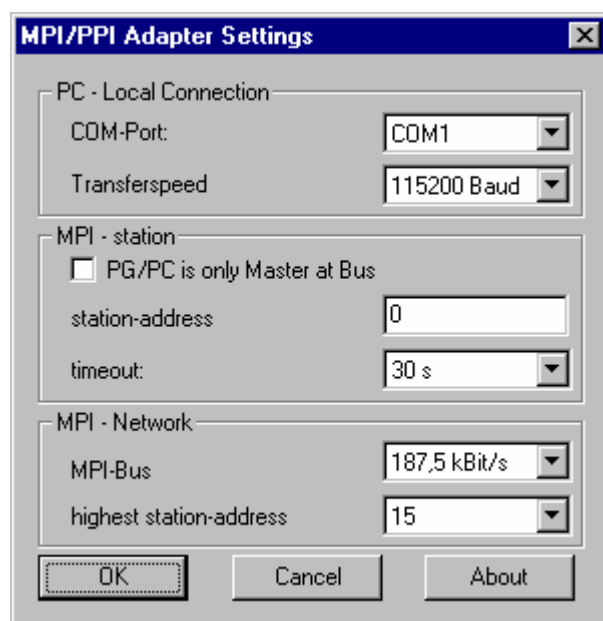

In this dialog are all possible settings at one place:

<i>COM-Port</i>	serial interface at which the MPI/PPI-adapter is connected
<i>Transferspeed</i>	You could choose between the following baud rates: 19200 Baud 38400 Baud (Default) 57600 Baud (only MPI -adapter) 115200 Baud (only MPI-adapter)
<i>PG/PC is only Master</i>	This setting should always switched OFF.
<i>Station-address</i>	This is the local station-number of the MPI/PPI-adapters. Each member in an MPI/Profibus must have a different number, which could edited in this field. Default is 0.
<i>Timeout</i>	Protocol-timeout, there are the following values possible: 10s 30s (Default) 100s
<i>MPI-Bus</i>	This is the transfer speed at the MPI/Profibus. The default is 187.5kBaud, the MPI/PPI-adapter could also use 19200 Baud (S7-300/400 as master and S7-200 as Slave)

highest station-address This is the highest possible station-address at the MPI/Profibus. All higher station-numbers are not linked in the bus.

9.9.1 MPISpeed-TrayIcon

If the system detects a Siemens-Version V5.1 ServicePack 2 or higher, a little TrayIcon is additionally installed, which shows the state of the driver.:



MPISpeed is yet NOT active

or



MPISpeed is yet ACTIVE

With a right Mouse-click a Sub-Menu is displayed:



Öffnen Opens a window which shows the state and properties of the driver..

RUN The MPI-Speed-Driver is always active, even when the S7-application is not loaded.

STOP The MPI-Speed-Driver is never active.

AUTO The MPI-Speed-Driver is activated, when the original S7-application is started and the driver „MPI-Speed 57/115kBit/s“ is selected

Beenden Exits this application.

A double-click on the MPISpeed-TrayIcon or selecting „Öffnen“ in the menu, the state-window is opened:

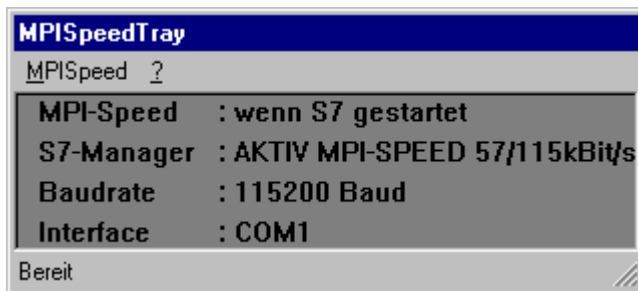

In this window the following information's are displayed:

MPI-Speed Shows the actual selection:
 „IMMER EIN“ MPI-Speed is active
 „IMMER AUS“ MPI-Speed is never active
 „wenn S7 gestartet“ MPI-Speed is active when S7 is started.

S7-Manager only displayed when the selection is „AUTO“.
 „AKTIV“ S7 runs and MPI -Speed is selected as Driver
 „aktiv“ S7 runs but another driver is selected
 „nicht aktiv“ S7 is NOT running

Baudrate used Baudrate

Interface used COM-Interface

Handbook Cable & Adapter

The menu has the following points:

Schließen Closes the state-window.

RUN The MPI-Speed-Driver is always active, even when no original S7-application is running.

STOP The MPI-Speed-Driver is never active.

AUTO The MPI-Speed-Driver is activated automatically, when the original S7-application is running and the driver „MPI-Speed 57/115kBit/s“ was selected.

Beenden Exits this application.

10 PG-COM / PG-UNI / PG-UNI-II

(CONVERTER RS232-TTY)

The PG-COM, PG-UNI and the PG-UNI-II connect the unit PC about the serial interface (COM 9-pol) with the PG-Port of a Siemens SIMATIC-S5 (TTY/20mA).

10.1 Operatin Instruction

The **PG-COM** uses the **5VDC**-powersupply of the Siemens PLC to supply of the internal electronics of the cable.

The **PG-UNI** and the **PG-UNI-II** however uses the **20mA**-current sources of the Siemens PLC around to produce the power supply of the internal electronics.

The PG-UNI-II is a further advancement of the PG-UNI. The difference is, that in the PG-UNI-II is integrated for the supervision of the interface-communication two LED's. The PG-UNI-II is protected against ESD shocks and the SUB-D plug casing is a metal casing. In fact of this, the PG-UNI-II is made to work in a harsh environment.

green LED: Communication to the RS232-interface

yellow LED: Communication to the TTY-interface

10.2 Circuit diagram PG-COM

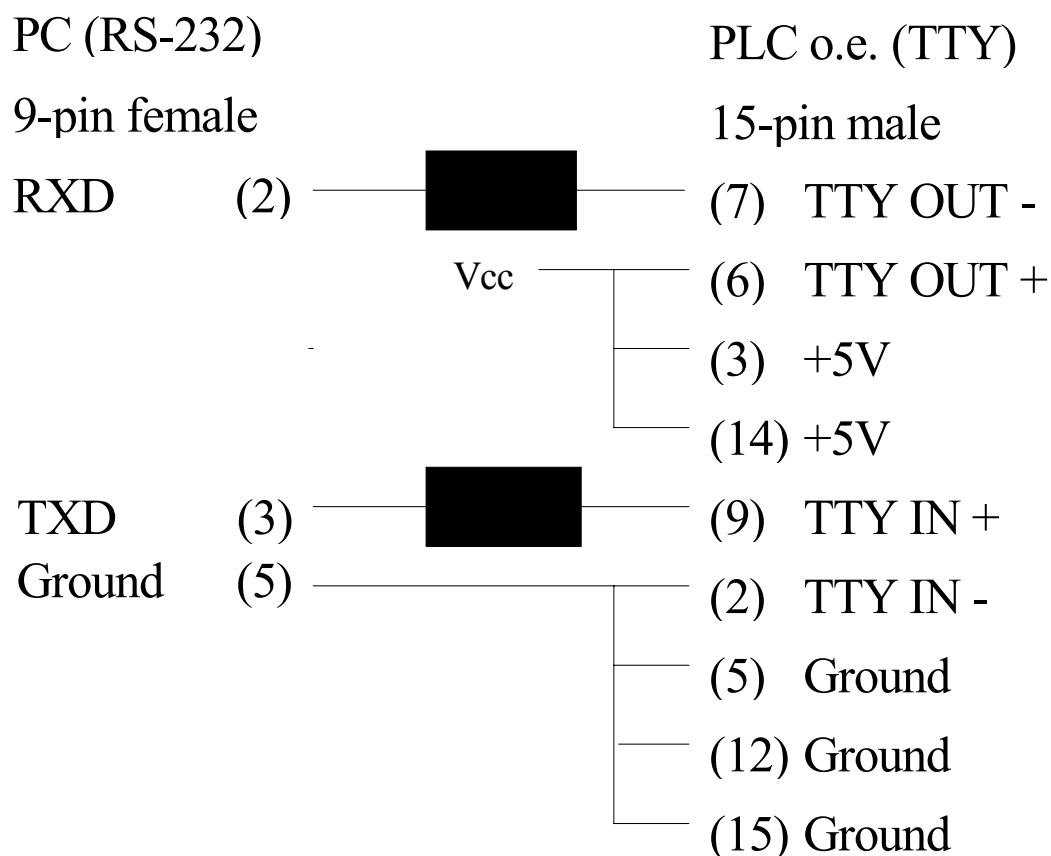

Order description

PG-COM (3m)

Art.Nr. 9359

PG-COM (5m)

Art.Nr. 9359.05m

PG-COM (10m)

Art.Nr. 9359.10m

PG-COM (15m)

Art.Nr. 9359.15m

(15m is the maximum length of the PG-COM. You can't get delivered a longer cable in any way).

10.3 Circuit diagram PG-UNI

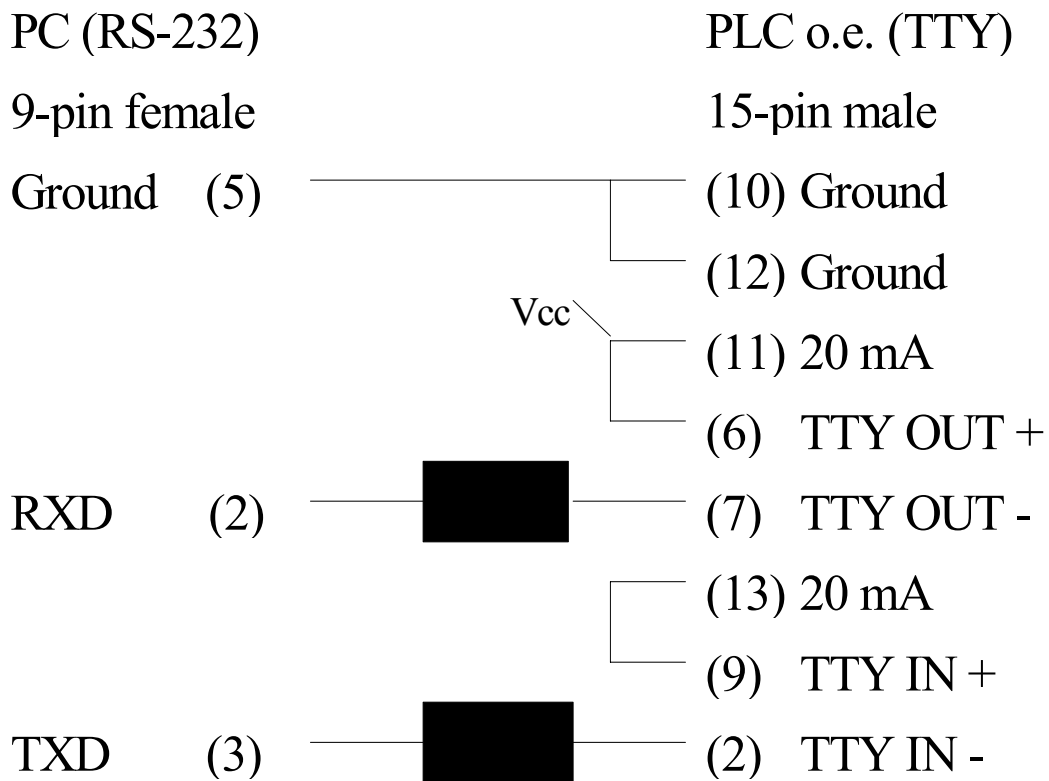

Order description

PG-UNI (10cm)	Art.Nr. 9359-3.10C
PG-UNI (3m)	Art.Nr. 9359-3
PG-UNI (5m)	Art.Nr. 9359-3.05m
PG-UNI (10m)	Art.Nr. 9359-3.10m

(for greater lengths of the PG-UNI-cable see point 11 page 177)

10.4 Circuit diagram PG-UNI-II

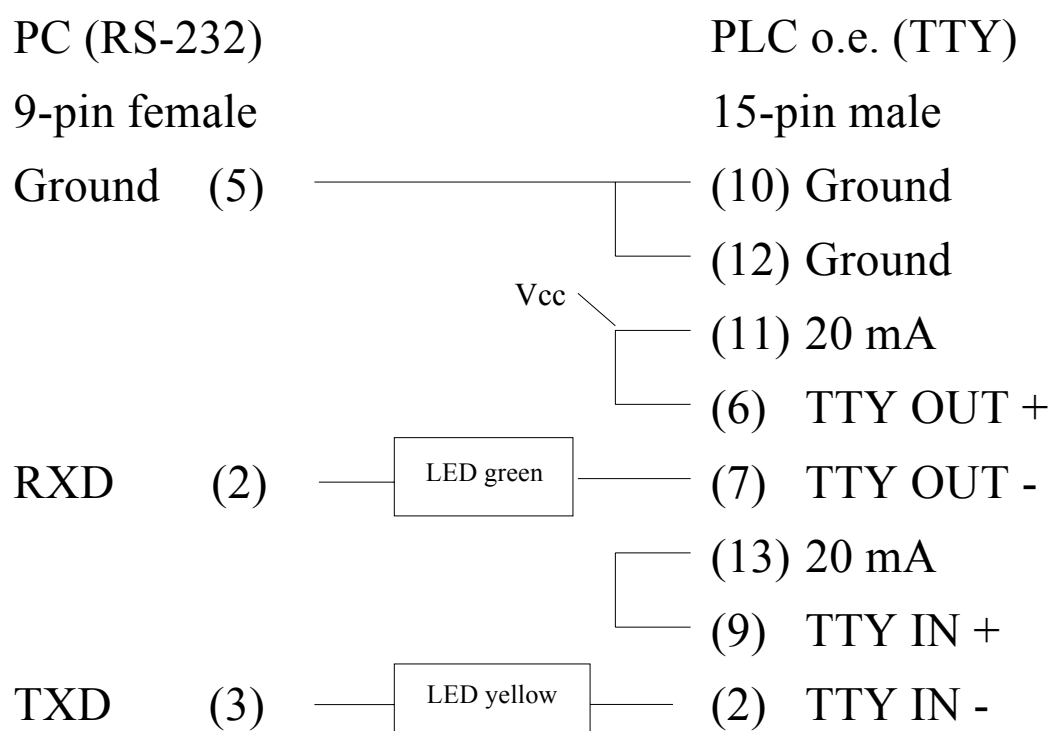

Order description

PG-UNI-II (3m)

Art.Nr.9359-2

PG-UNI-II (5m)

Art.Nr.9359-2.05m

PG-UNI-II (10m)

Art.Nr.9359-2.10m

(for greater lengths for the PG-UNI-II see point 11 page 177)

11 Prolongation of PG-UNI and PG-UNI-II

It is possible with the PG-UNI-prolongation, to prolongate the PG-UNI up to 300m at the TTY side. You can prolongate on the same way the PG-UNI-II, too.

Order Description

PG-UNI-Verlängerung (PG-UNI-prolongation)	Art.Nr. 9390
PG-UNI + Verlängerung (PG-UNI-prolongation)	Art.Nr. 9359-3 + 9390
PG-UNI-II + Verlängerung (PG-UNI-II + prolongation)	Art.Nr. 9359-2 + 9390

12 UNI-prolongation-set

The UNI-Verlängerungsset (UNI-prolongation-set) contains the complete material (without prolongation cable) which is necessarily for the making of a UNI-prolongation. A corresponding wiring diagram for the soldering to the SUB-D plugs is enclosed.

Recommended cable: 2x2x0,25mm² in twisted pairs with shield.

Order Description

PG-UNI-Verlängerungsset (PG-UNI-prolongation-set)	Art.Nr. 9359-7
---	-----------------------

13 PG-USB

The PG-USB is a active cable for connecting a Siemens X4/X5-Port to the PC USB-Port. The cable needs **no** external

Handbook Cable & Adapter

supply to work. It takes its power out of the PC. This supply is also be used to make the cable active on his PLC-side. The cable is be connected to the 15pin TTY port of the PLC or CP and is connected to the PC USB-Port. The software-driver are run able for Windows 98, Me and WIN2000. The driver is not certified for Windows XP, but do only ignore the messages doing installation.

The communication with this cable uses a virtual COM-port. Only original 32bit-programms can work with this driver.

13.1 Pinning

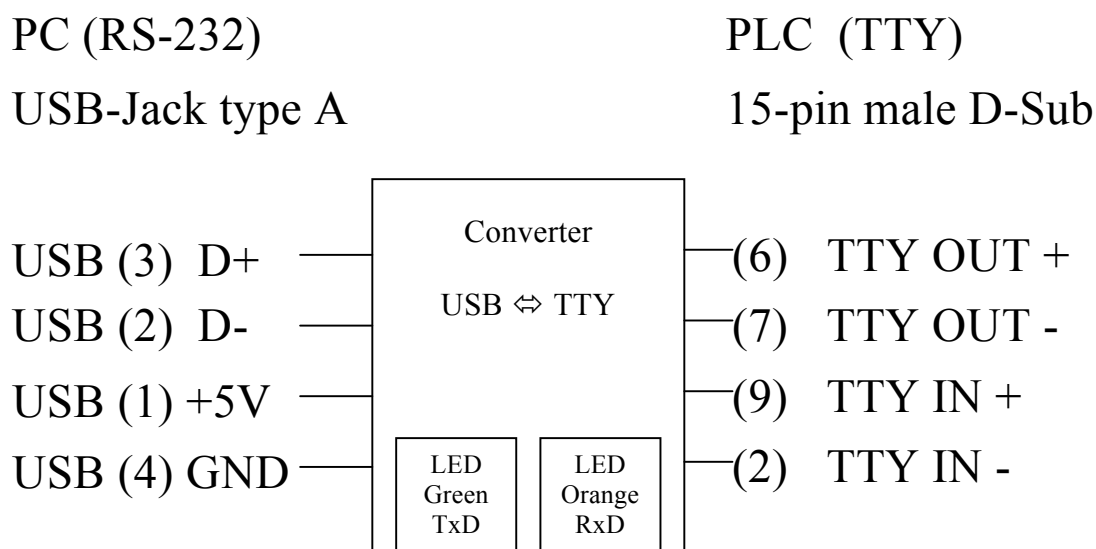

PG-USB (3m)

Art.Nr. 9359-1

13.2 PG-USB-prolongation

The PG-USB is active on his PLC-side. To increase the lengthening, you need only a 4 wire cable. You must connect the following pins: 2-2/6-6/7-7/9-9. Both shielding-sides

should be connected at the metal-case of the SUB-D-plug. Recommended cable: 2x2x0,25mm² in twisted pairs with shield. Maximum length: 100m.

13.3 Driver-Installation

The cable would be connected to your pc to a free USB-Port for first time. Your PC specially your OS recognises the cable and looks for the correct driver. Please give for the OS the DemoCD for source. Your OS recognises the data for installation and install the correct driver. Follow the parameters of the driver for installation.

After installation of the driver, you should select in your PC DeviceManager → „View Devices By Type“ → „Ports (COM & LPT)“ the USB serial port. Click properties, select port settings and change the parameters to following:

Bits per second:	9600
Data:	8
Parity:	Even
Stop bits:	2
Protocol:	No

These parameters are active, after closing this dialog. Please change in your application the COM-Port to the virtual COM-port, so you can work with this driver.

13.4 Original-S5 in a MS-DOS-Box

Because the Original-S5 is running in a MS-DOS-Box, a special installation is needed.

Inserting the Mega-Toolbox CD, there will be starting a little application, which displays the following dialog:

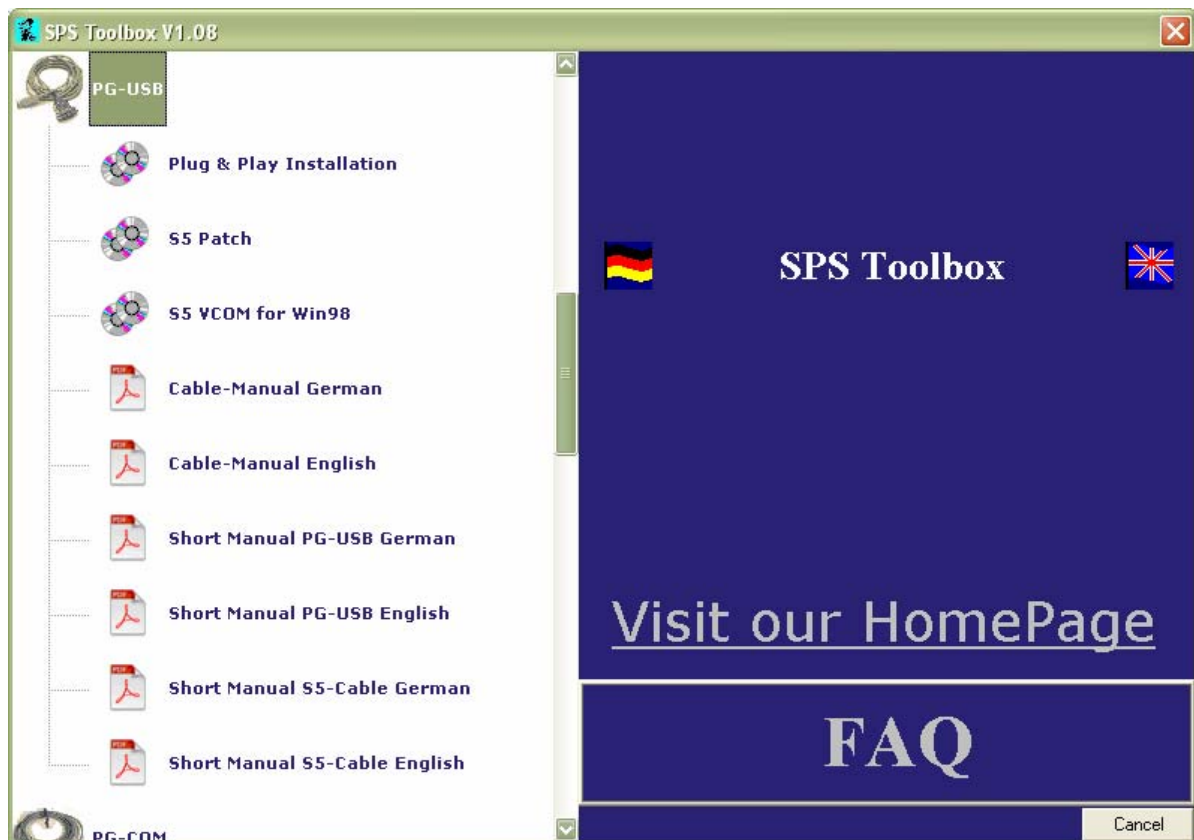

Click on PG-USB to expand the menu. Click on „S5 Patch“ to start the installation assistant which guides you through the driver installation.

Choose the desired language. Select the PG-USB cable and confirm with „OK“. Press „Install“ and choose the folder where the S5 software is installed. The installation routine is now searching for the S5 software. Next you have to select the used COM port. Then the S5 patch will be installed. Press „End“ as soon as the installation is completed.

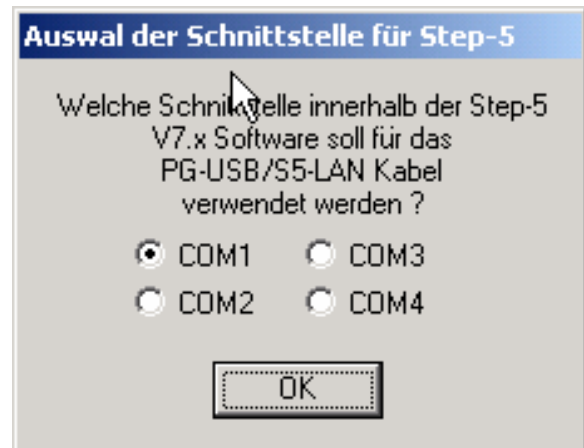
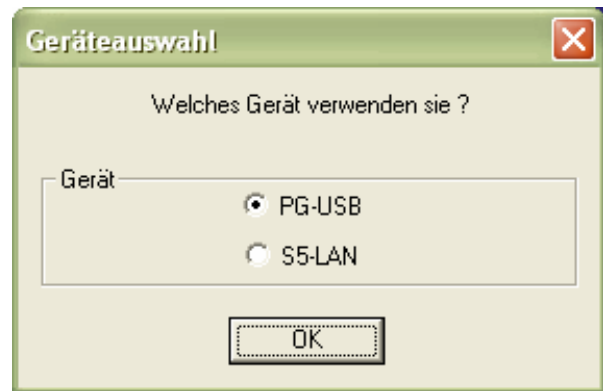

Attention: For the Step5-Original application there **must** be one COM1 to COM4 selected. If necessary change the COM port. Go to the Control Center, select “System”. In the Tab “Hardware“, click button „Device manager“. In the Device-Manager the virtual COM-Port is listed in the section “Interfaces (COM and LPT)”, Right click „USB Serial Port (COMx)“, in the Context Menu choose “Properties”. In the following dialog select the tab „Port Settings“. Click onto the button „Advanced“, in the next dialog you could choose the COM-Port.

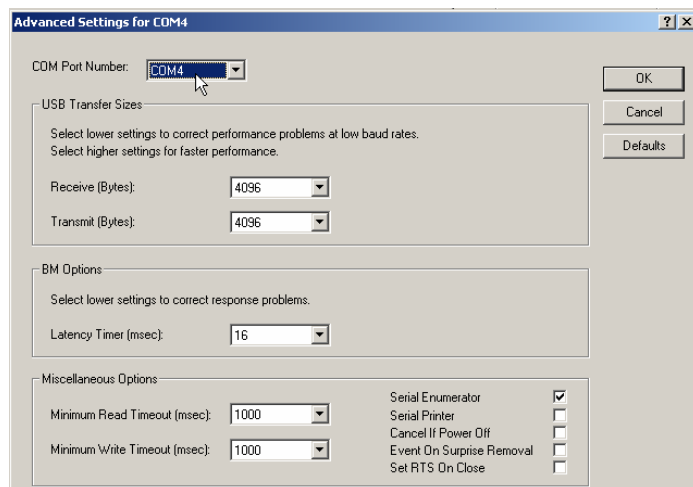

13.5 Driver for Windows 98

Under Windows 98 could not access directly a virtual COM-Port out of a MSDOS-Box like XP or 2000. Therefore a additionally driver-installation „S5VCOM for Win98“ is needed.

13.5.1 Installation

- 1.) Connect the PG-USB - Cable to your PC on an USB-Port.
- 2.) If not done yet, install the Driver for the PG-USB Cable (Accessing the S5-PLC from **Windows**-Applications)
- 3.) Test the connection to the S5-PLC with a Windows-application (f.e. **PG2000** from this CD)
- 4.) Start the application **SETUP.EXE** from the Installation-CD for „S5VCOM für Win98“
- 5.) Select the Installation-Path → click Next
- 6.) Select the Name of the Startmenu → click Next
- 7.) After the End of the Installation the PC must be rebootet

S5 VCOM is installed into the Autostart-Directory and is started every time the PC boots.

13.5.2 Deinstallation

- 1.) in “Start → Properties → Settings“ click on **Software**
- 2.) select „S5 VCOM für Win98“ and click on “change/delete“
- 3.) Do you really want to delete the application, click “Yes“
- 4.) If not used any more, you could deinstall the driver for the PG-USB Cable „FTDI USB<->Serial“
- 5.) Reboot your PC (recommended)

13.5.3 Configuration / Start

After Installation and reboot of the PC, the S5VCom-Driver will start automatically. If an error occurs while Installation or Starting of driver, a message is shown.

If correctly installed, on the bottom-right Corner of the Screen a new Tray-Icon is displayed:



Handbook Cable & Adapter

This Tray-Icon shows, if a PG-USB-Cable is connected or not, and if a communication is in progress:



PG-USB Cable is not connected or detected



PG-USB Cable is connected, but no communication



PG-USB Cable is connected, the interface is communicating

S = Sending (from PC to S5)

E = Receiver (from S5 to PC)

If you double-click on the Tray-Icon a new Dialog is displayed:



In the section State is displayed which Interface-Cable is used for communication and if a connection exists.

In the section virtual Port the following information is shown:



On the left side is the COM - Port which is used from Windows-Software (You could choose this COM-Port in the Settings under „System/Hardware/Device Manager/COM and LPT-Interface “ at „USB Serial Port/Properties/Extend“.

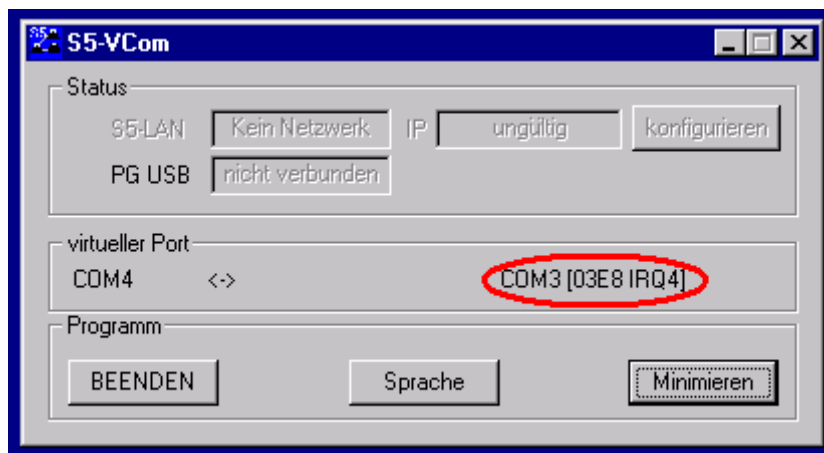

On the right side is the COM-Port (IO-Ports) of the MS-DOS Box shown. This COM-Port should be selected in the S5-Software.

Handbook Cable & Adapter

According which COM - Ports already exists, the next free COM-Port will be used:

<u>existing COM</u>	<u>from S5VCOM used</u>
NONE	COM1 [03F8h,IRQ4]
COM1	COM2 [02F8h,IRQ3]
COM2	COM1 [03F8h,IRQ4]
COM1,COM2	COM3 [03E8h,IRQ4]
COM1,COM3	COM2 [02F8h,IRQ3]
COM2,COM3	COM1 [03F8h,IRQ4]
COM1,COM2,COM3	COM4 [02E8h,IRQ3]

In the section Program you could exit the application, change the language of the application or minimize to the tray-icon.

13.5.4 Frequently asked questions

Trying to execute the Installation a message is displayed, which states that this software is not installed under Windows XP/NT/2000.

The S5VCOM-Driver is ONLY needed for Windows 95/98/Me. The other Operating Systems like Windows XP/2000 has this driver built-in and we don't need it then.

There is a message displayed, that the PG-USB-Driver is not installed

The S5VCOM-driver use the normal Windows-driver for the PG-USB Cable, so this driver must be installed before this S5VCOM-Driver. Connect the PG-USB Cable in an USB-Port and follow the Installation-Instructions. (This driver is on the CD)

While copying the files to the hard-disk an error-message is displayed which states that copying is not possible

This could be several Causes. Eventually you have too less disk-space or the application is already installed or the Tray-Icon is already running

After restart of the PC a message is displayed which states that the file Settings.ini could not be opened.

The settings are saved in this file in the Installation-directory of the S5VCOM-driver. If this file does not exists, it will be created at exit of the application or this file is write-protected or you have no write-access to this file

After restart of the PC a message is displayed which states that Drive is not loaded and the Tray-Icon is closed.

There is no usefull COM-Port founded, so the driver is not loaded. Start a MSDOS Box and type in:

„debug <ENTER> “

„d 40:0<ENTER> „

There will be displayed a Hexdump of the BIOS-Configuration (in which the existing COM-Ports also situated)

Input „q<ENTER> “ to exit the application:

Handbook Cable & Adapter

```
c:\cmd.exe
c:\Arbeit>debug
-d 40:0
0040:0000 F8 03 F8 02 E8 03 E8 02-BC 03 78 03 78 02 80 9F .....x.x...
0040:0010 23 C8 00 80 02 28 80 20-00 00 2C 00 2C 00 64 20 #...<...d
0040:0020 20 39 34 05 30 0B 3A 34-30 0B 0D 1C 00 00 00 00 94.0.:40...
0040:0030 00 00 00 00 00 00 00 00-00 00 00 00 00 00 80 .....
0040:0040 D2 00 C3 00 0F DD C5 E0-CA 03 50 00 00 10 00 00 .....P...
0040:0050 00 08 00 00 00 00 00 00-00 00 00 00 00 00 00 .....
0040:0060 0F 0C 00 D4 03 29 30 7F-03 00 C0 00 71 1D 0B 00 .....>0...q...
0040:0070 00 00 00 00 00 00 00 00-14 14 14 00 01 01 01 01 .....
-q
c:\Arbeit>
```

*In the first 4*2Byte are displayed the existing COM-Ports*

F8 03 COM1

F8 02 COM2

E8 03 COM3

E8 02 COM4

00 00 Empty (here not existing)

*In the displayed Snap-Shot there is no free COM -Port
If an Empty slot is existing, so only the corresponding
IRQ could not be used.*

COM1 and COM3 use both the same IRQ4

COM2 and COM4 use both the same IRQ3

S5VCOM uses COM3 in the MSDOS-Box, my S5-Software could only use COM1 or COM2 (f.e.: S5 V3.02)

*Try to switch the existing COM1/2 to COM3/4
(eventually by Jumper)*

My Windows-Software could not communicate with the PG-USB - Kabel, the setting is correct and the cable works before. There is a message that the COM - Port is used or not accessible.

*The S5VCOM-Driver opens this COM - Port to communicate even when no MSDOS - Box is opened. The Windows-application want to open the same COM – Port. Exit the S5VCOM-application (Tray-Icon), after that the COM-Port is usable under Windows, the access out of the MSDOS - Box is then **not possible**. Restart the application from the AutoStart – directory to reactivate the MSDOS – Box. The Access under Windows and under MSDOS is **excluded** together !*

It don't works, although the driver is loaded and the Tray-Icon is startet.

Double-click onto the Tray-Icon, select from the System-Menu „Info about ...“:

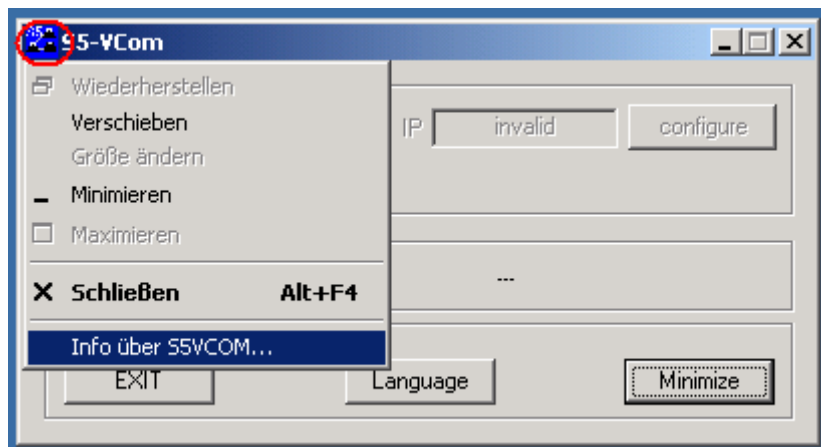

Handbook Cable & Adapter

*A new dialog is displayed, in this dialog the version of the driver is shown. Click with the **right** Mousekey over the Image, there will pop-up some buttons, click **ONLY** onto the button **VCOMLOG**:*

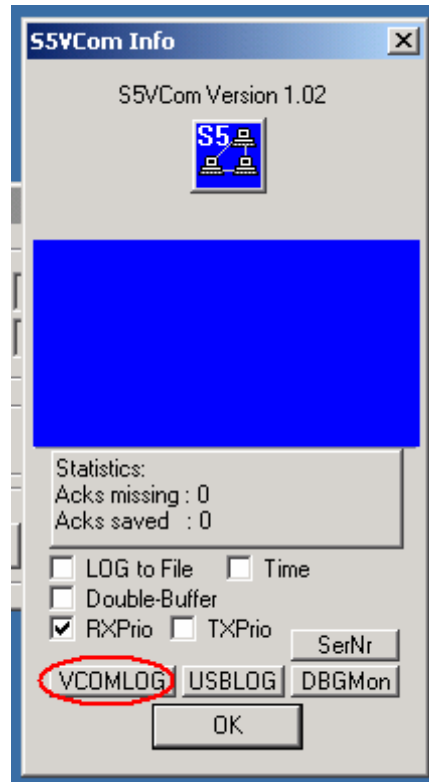

Confirm this with "OK". There will be a new file in the Installation-directory from S5VCOM named „VCOM.LOG“, send us this file together with the version and a description of your problem.

If your problem could not be solved, call our support.

14 USB-Serial-Converter

14.1 Description

The USB-Serial-Converter is used to convert serial signals (from the serial end) to a USB interface.

14.2 Driver installation

The installation is equal to the PG-USB driver installation. First insert the SOFTW_TREIBER_CD into your drive and wait until the auto start loads the Mega dialog. If this dialog does not appear within a few seconds please click on mega.exe in the root path of the disc.



Expand the “PG-USB” menu and click on “Plug & Play Installation” to start the driver installation assistant.

Order Description

USB-Serial-Converter

Order No. 9350-1-RS232

15 Adaptors for PG-UNI / PG-UNI-II / PG-USB

15.1 Netzadapter (not for PG-USB):

The Netzadapter generates the 20mA current sources for the send- and the receive-path at the TTY-interface.

(necessary at passive TTY-interfaces as e.g. IP266 and other pieces of equipment without or faulty current sources)

The power supply of the Netzadapter is been carried out through 12-24VDC.

15.1.1 Circuit diagram NETZ-Adapter

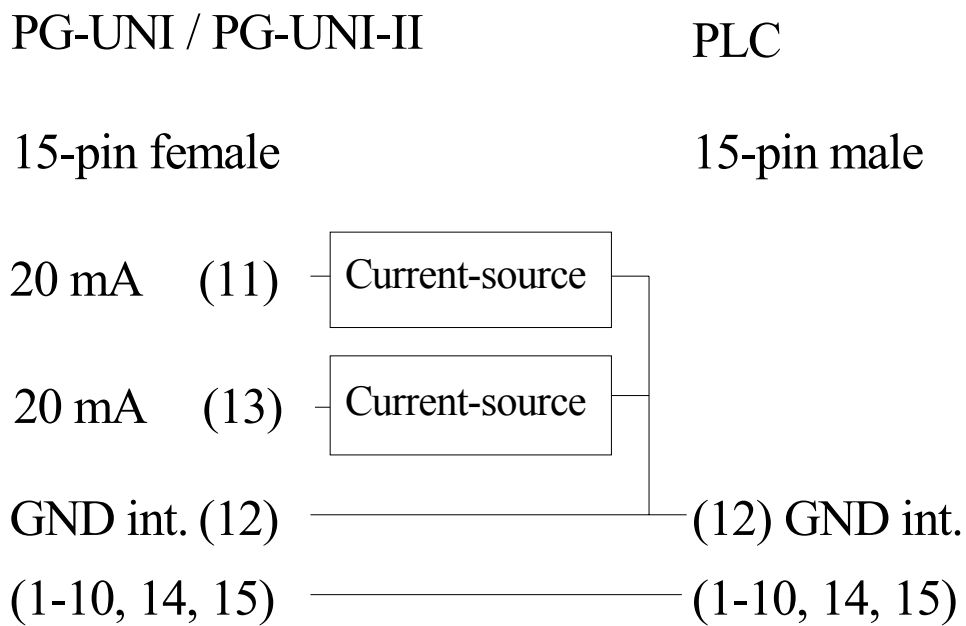

Order Description

Netz-Adapter

Art.Nr. 9359-4

15.2 PG-ISO-Adapter

The PG-ISO-Adapter generates the 20mA current sources for this send and receive path at the TTY-interface from the Siemens-side-available power supply of 5 and/or 24V.

Decoupling up to 1000V.

15.2.1 Circuit diagram PG-ISO-Adapter

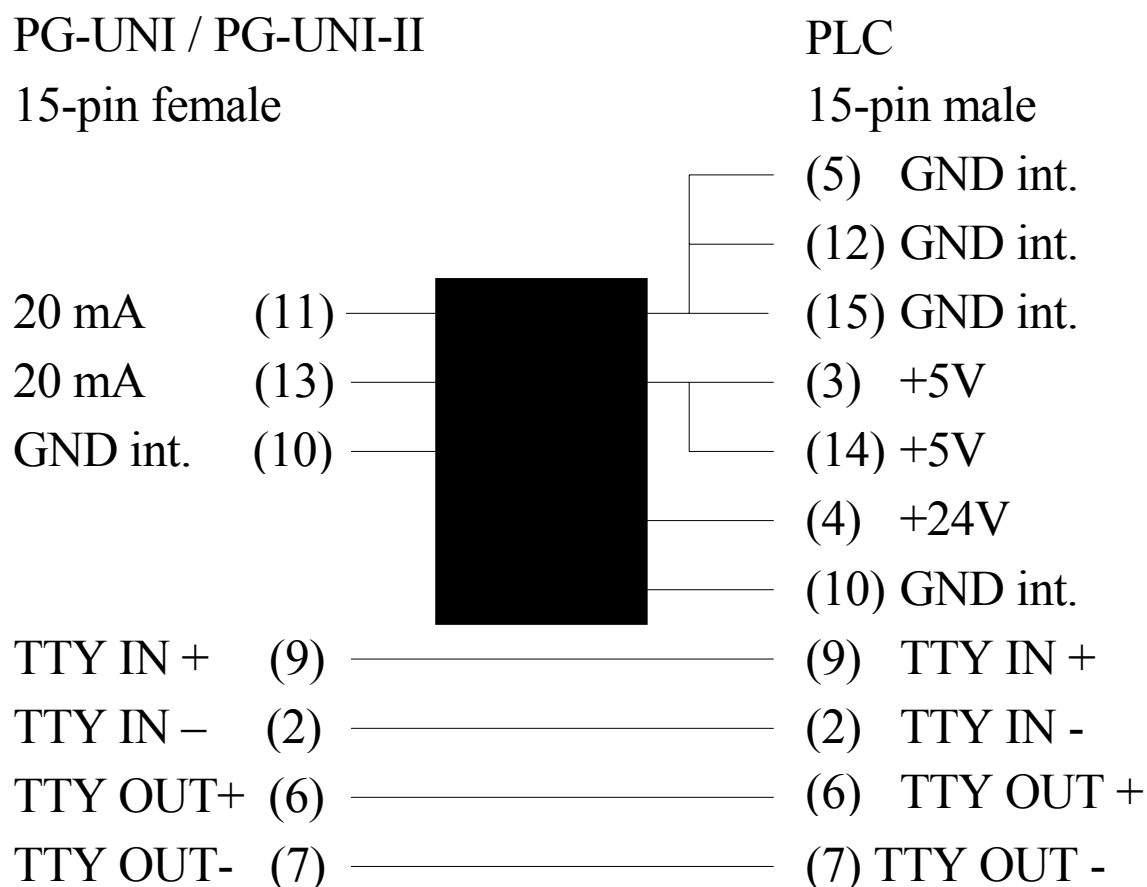

Order Description

PG-ISO-Adapter

Art.Nr. 9359-8

15.3 CP525-Adapter

The CP525-Adapter connects the PG-UNI / PG-UNI-II with the **PG-Port** from a CP525.

(For the connection at other CP assemblies see release table point 14.)

15.3.1 Plug design

PG-UNI / PG-UNI-II-side:

15pol. SubD-female with locking bolts

CP-side:

25pol. SubD-male with sliding coupling

Order Description

CP-525-Adapter

Art.Nr. 9359-5

15.4 CP525-Adapter for PG-USB

The CP525-Adapter connects the PG-USB with the **PG-Port** from a CP525.

(For the connection at other CP assemblies see release table point 12.)

15.4.1 Plug design

PG-USB-side:

15pol. SubD-female with locking bolts

CP-side:

25pol. SubD-male with sliding coupling

Order Description

CP-525-Adapter for PG-USB

Art.Nr. 9359-5-USB

15.5 CP525-K-Adapter

The CP525-K-Adapter connects the PG-UNI / PG-UNI-II with the **Communication-Port** of a CP525.

This adapter is also suitable for following assemblies:
CP524, SAS523/525.

15.5.1 Plug design

PG-UNI / PG-UNI-II-side:

15pol. SubD-female with locking bolts

CP-side:

25pol. SubD-male with sliding coupling

Order Description

CP-525-K-Adapter

Art.Nr. 9359-5K

15.6 CP525-K-Adapter for PG-USB

The CP525-K-Adapter connects the PG-USB with the **Communication-Port** of a CP525.

This adapter is also suitable for following assemblies:
CP524, SAS523/525.

15.6.1 Plug design

PG-USB-side:

15pol. SubD-female with locking bolts

CP-side:

25pol. SubD-male with sliding coupling

Order Description

CP-525-K-Adapter for PG-USB

Art.Nr. 9359-5K-USB

15.7 SINUM-Adapter

The SINUM-Adapter connects the PG-UNI-cable with a SINUMERIK.

15.7.1 Plug design

PG-UNI /PG-UNI-II-side:

15pol. SubD-female with locking bolts

Sinumerik-side:

25pol. SubD-male with sliding coupling

Order Description

Sinum-Adapter

Art.Nr. 9359-6

15.8 SINUM-Adapter for PG-USB

The SINUM-Adapter connects the PG-USB-cable with a SINUMERIK.

15.8.1 Plug design

PG-USB-side:

15pol. SubD-female with locking bolts

Sinumerik-side:

25pol. SubD-male with sliding coupling

Order Description

Sinum-Adapter for PG-USB

Art.Nr. 9359-6-USB

15.9 AG150-Adapter

The AG150-Adapter connects the PG-UNI / PG-UNI-II with a AG150-Simatic (AS511).

PG-UNI / PG-UNI-II **only** in connection with the Netzadapter, because the interface port of the AG150 is passive.

15.9.1 Plug design

PG-UNI / PG-UNI-II-side (Netzadapter-side):

15pol. SubD-female with locking bolts

PLC-side:

25pol. SubD-female with sliding coupling

Order Description

AG-150-Adapter

Art.Nr. 9359-5-150

15.10 AG150-Adapter for PG-USB

The AG150-Adapter connects the PG-USB with a AG150-Simatic (AS511).

15.10.1 Plug design

PG-USB-side:

15pol. SubD-female with locking bolts

PLC-side:

25pol. SubD-female with sliding coupling

Order Description

AG-150-Adapter for PG-USB

Art.Nr. 9359-5-150-USB

15.11 WF470-Adapter

The WF470-Adapter connects the PG-UNI / PG-UNI-II with a WF470.

PG-UNI / PG-UNI-II **only** in connection with the Netzadapter, because the interface-port of the WF470 is passive.

15.11.1 Plug design

PG-UNI / PG-UNI-II-side (Netzadapter-side):

15pol. SubD-female with locking bolts

WF470-side:

25pol. SubD-female with sliding coupling

Order Description

WF470-Adapter

Art.Nr. 9359-5-WF470

15.12 WF470-Adapter for PG-USB

The WF470-Adapter connects the PG-USB with a WF470.

15.12.1 Plug design

PG-USB-side:

15pol. SubD-female with locking bolts

WF470-side:

25pol. SubD-female with sliding coupling

Order Description

WF470-Adapter for PG-USB Art.Nr. 9359-5-WF470-USB

15.13 25pol. PC-Connector (male/female)

The PG-UNI and the PG-COM will be delivered as default with a 9-pol. Sub-D plug.

The following variants are offered as special version:

- 25pol female (COM2 at standard-IBM comp. PC's)
- 25pol male (e.g. COM1 Siemens PG720)

Order Description

Zuschlag 25pol.Stecker Art.Nr. 9310

(please indicate if female or male-plug)

15.14 Special Versions

You can allways on every time ask us for speciall versions, adaptors for your cables, for speciall machines. Call us and tell us, what you need, give us the correct pinning, we will proof it and will produce it, if you want.

16 RELEASE TABLE

Devicetype	PG-UNI + PG-UNI-II	PG-USB	PG-COM	PG-ISO-SET (1000V) = PG-UNI + PG-ISO-Adapter
S5-90U	Release	Release	Release	Release
S5-95U	Release	Release	Release	Release
S5-100U	Release	Release	Release	Release
S5-115U	Release with CPU-944 + PG-ISO-Adapter ¹⁾	Release	Release	Release
S5-135U	Release	Release	Release	Release
S5-155U	Release	Release	Release	Release
S5-AG110S	+ AG150-Adapter + NETZ-Adapter	+ AG-150-Adapter for PG-USB-Kabel	-	+ AG150-Adapter + NETZ-Adapter ²⁾
S5-AG130W/B	+ AG150-Adapter + NETZ-Adapter	+ AG-150-Adapter for PG-USB-Kabel	-	+ AG150-Adapter + NETZ-Adapter ²⁾
S5-AG150A/K/S/U	+ AG150-Adapter + NETZ-Adapter	+ AG-150-Adapter for PG-USB-Kabel	-	+ AG150-Adapter + NETZ-Adapter ²⁾
CP-143	Release	Release	-	Release
CP-521	+ CP521-Adapter	-	-	+ CP521-Adapter ²⁾
CP-523	+ CP523-Adapter	-	-	+ CP523-Adapter ²⁾
CP-525	+ CP525-Adapter	+ CP525-Adapter for PG-USB-Cable	-	+ CP525-Adapter ²⁾
CP-526	Release	Release	-	Release
CP-527	Release	Release	-	Release
CP-528	Release	Release	-	Release
CP-544	Release	Release	-	Release
CP-5430	Release	Release	-	Release
CP-5431	Release	Release	-	Release
IP-246	Release	Release	-	Release
IP-247	Release	Release	-	Release
IP-252	Release	Release	Release	Release
IP-266	+ NETZ-Adapter	Release	-	+ NETZ-Adapter ²⁾
WF-470	+ WF470-Adapter + NETZ-Adapter	+ WF470-Adapter for PG-USB-cable	-	+ WF470-Adapter + Netz-Adapter ²⁾
SIN-805	+ SINUM-Adapter	+ Sinum-Adapter for PG-USB-Kabel	-	+ SINUM-Adapter ²⁾
SIN-810	+ SINUM-Adapter	+ Sinum-Adapter for PG-USB-Kabel	-	+ SINUM-Adapter ²⁾
SIN-820	+ SINUM-Adapter	+ Sinum-Adapter for PG-USB-Kabel	-	+ SINUM-Adapter ²⁾
SIN-840	+ SINUM-Adapter	+ Sinum-Adapter for PG-USB-Kabel	-	+ SINUM-Adapter ²⁾
SIN-850	+ SINUM-Adapter	+ Sinum-Adapter for PG-USB-Kabel	-	+ SINUM-Adapter ²⁾
SIN-880	+ SINUM-Adapter	+ Sinum-Adapter for PG-USB-Kabel	-	+ SINUM-Adapter ²⁾
Maximum prolongation	300m over UNI-prolongation	100m over PG-USB-prolongation	-	300m over UNI-prolongation

¹⁾ At the CPU 944 up to and including year of construction 12.'94 it is necessary to use an ISO-Adapter.

²⁾ The ISO-Adapter cannot be used since the assembly doesn't deliver the necessary power supply on the PG interface at this constellation.

17 SC-09

(CONVERTER RS232-RS422/485)

The SC-09 connects the serial interface from a PC (COM 9-pol) with the programming interface from a Mitsubishi-PLC (Fx - and A - Serie).

It is possible to connect with the contained adapter PLC's which has a 25-pol. Sub-D or a 8-pol. Mini-DIN programming port.

17.1 Pin configuration RS232

Pin.Nr.	notation	signalname	In/Out
1	N.C.	Not Connectet	
2	TXD	Transmitted Data	Out
3	RXD	Received Data	In
4	N.C.	Not Connectet	
5	GND	Signal Ground	
6	N.C.	Not Connectet	
7	CTS	Clear to Send	In
8	RTS	Request to Send	Out
9	N.C.	Not Connectet	
Shield		Shield on GND (Pin 5)	

17.2 Pin configuration RS422/485

Pin.Nr.	notation	signalname	In/Out
1	N.C.	Not Connectet	
2	TXD+	Transmitted Data +	Out
3	RXD+	Received Data +	In
4	RTS+	Request to Send +	Out
5	CTS+	Clear to Send +	In
6	N.C.	Not Connectet	
7	GND	Signal Ground	
8	GND	Signal Ground	
9	N.C.	Not Connectet	
10	N.C.	Not Connectet	
11	N.C.	Not Connectet	
12	VCCin	+5V DC Input Voltage	In
13	VCCin	+5V DC Input Voltage	In
14	N.C.	Not Connectet	
15	TXD-	Transmitted Data -	Out
16	RXD-	Received Data -	In
17	RTS-	Request to Send -	Out
18	CTS-	Clear to Send -	In
19	N.C	Not Connectet	
20	connect	connection to Pin 21	
21	connect	connection to Pin 20	
22	N.C.	Not Connectet	
23	N.C.	Not Connectet	
24	VCCin	+5V DC Input Voltage	In
25	VCCin	+5V DC Input Voltage	In
Shield		Shield on GND	

17.3 Plug design

Mitsubishi PLC:

Alternatively 25pol. SUB-D or 8pol. Mini-DIN-connector

PC:

9pol. SUB-D female with PC-locking screws

Order Description

SC-09-Kabel (3m)

Art.Nr. 9359.M